

Lightwave Catalog 2011

Enabling Optical and Digital Innovation
Volume 1: General Photonic Test

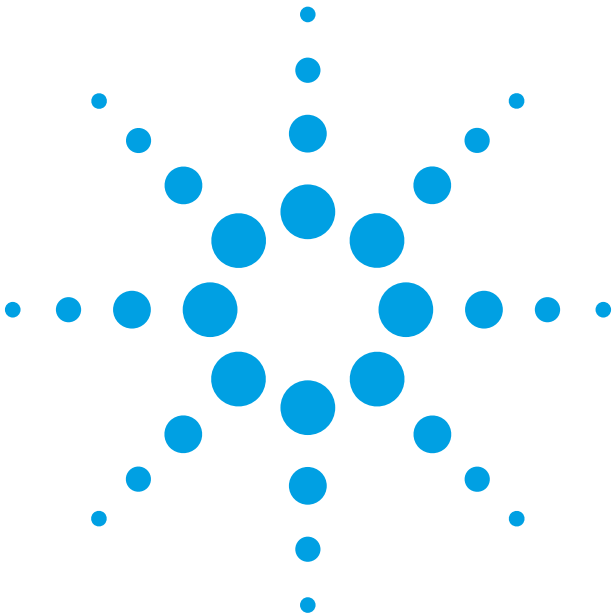

Agilent Technologies

Last year was widely celebrated as the year of the laser, recognizing the broad impact of lasers on our lives since the first demonstration half a century ago.



Nowhere is this impact stronger than in telecommunication and data transmission, where lasers and fiberoptics are crucial to increase transmission rates and distances, while controlling costs and energy consumption. More than ever, the communications industry is undergoing massive change and new challenges in the wireless, wireline, and computer segments. The explosive growth of multimedia applications, mobile services, social networking and high-bandwidth video demands significant bandwidth increases and lower power consumption at increased performance. Smartphones, notebooks, and tablets have pushed the limits of 3G networks, making the move to LTE/4G a critical priority.



The move of long-distance telecommunication towards advanced optical modulation drives a paradigm shift in the photonic industry. In computer systems, the need for optical interconnects to attach a diverse set of peripherals will increase dramatically. Keeping up with these changes, while maintaining revenue and service levels, is the critical success factor for the communication industry worldwide.

A handwritten signature in black ink, appearing to read 'Siegfried Gross', written in a cursive style.

Siegfried Gross
Vice President and General Manager
Digital Test Division

Introduction by Siegfried Gross 2

Volume 1: General Photonic Test

Applications: Swept-Wavelength Optical Measurement Solutions	4
Applications: Optical Transient Measurements	5
 8163B, 8164B and 77-Series of Optical Instruments	6
81600B Tunable Laser Modules	8
 8198xA, 8194xA and 81950A Compact Tunable Laser Source	10
 N7711A and N7714A Multiport Tunable Laser Source	12
81663A DFB Laser Modules	14
8165xA Fabry-Perot Laser Modules	15
N7744A and N7745A Optical Multiport Power Meter	16
8163xA/B and 8162xB Optical Power Meters	17
81610A and 81613A Return Loss Modules	21
8157xA High-Power Optical Attenuators	22
 N775xA and N776xA Multi-Channel Optical Attenuators	24
8159xB Modular Optical Switch	26
8169A Polarization Controllers	27
N7781B Polarization Analyzer	28
N7782B PER Analyzer and N7783B Thermal Cycling Unit	30
N7784B, N7785B, N7786B Polarization Controllers	32
N7788B/BD Optical Component Analyzer	34
86038B Photonic Dispersion and Loss Analyzer	36

Reference

Accessories 38

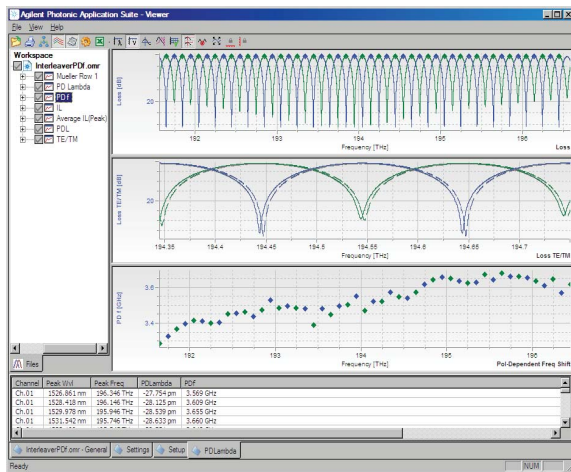

Swept-Wavelength Measurement Solutions

Tunable laser instruments are used for spectral measurements of optical components and materials. The wavelength dependence is rapidly determined with selectable and very high wavelength resolution. The measurement systems can be flexibly configured to match the requirements of the application. Here we suggest some examples.

Insertion loss measurement (IL)

Combining one or more optical power meters with the tunable laser source (TLS) permits measurement of optical power vs. wavelength. Often this is used to find the ratio of power at the input of a component to the output power, commonly called insertion loss and expressed in dB. While the TLS tunes the wavelength over the chosen range, the power meters periodically sample the power for the desired number of measurement points. These samples are synchronized with the TLS sweep with a trigger signal for accurate association with the corresponding wavelength. Use of multiple power meters allows simultaneous measurement of outputs from multipoint components like multiplexers, splitters and wavelength switches.

A setup can combine the Agilent 81600B, 81940A or 81980A TLS with power meters from the 816x-series modules or the new multipoint N7744A and N7745A and the free N7700A IL software. Easy programming of these "lambda scan" routines uses the free 816x Plug&Play driver and can be enhanced with the N4150A Photonic Foundation Library (PFL) of measurement functions. Reflection spectra (return loss) can also be measured, by connecting the 81610A return loss module after the TLS.

Performance considerations

High wavelength accuracy and repeatability, particularly during fast wavelength scans, is assured with the built-in wavelength monitoring in these laser sources. These "lambda-logging" data are synchronized with the measurement triggers to the power meters. And if even higher absolute wavelength accuracy is needed, an offset calibration against a gas cell reference can be used, as conveniently supported by the PFL.

InGaAs power detectors are best for such measurements due to the small variation in responsivity over the single-mode fiber wavelength range (1260-1630 nm) and high sensitivity and dynamic range. The new N7744A and N7745A power meters are especially well adapted to these swept-wavelength measurements with fast sampling rates and high signal bandwidth that allows high-resolution measurements at high

sweep speeds without distortion of the measurement trace. Faster data transfer raises throughput dramatically, especially at high port counts.

When insertion loss is low at some wavelengths and very high at others (high dynamic), like in DWDM components, it is very important that the broadband spontaneous emission from the TLS is very low. This avoids light transmitted in the passband of the component when the TLS wavelength is outside this band. The 81600B TLS provides light with very low source spontaneous emission (SSE), especially for components with more than 40-50 dB dynamic. The dynamic range of the power meters is then important too. Sometimes this is extended by measuring with multiple power ranges and "stitching" the traces to capture both the strongest and weakest signal. This stitching is provided by the 816x P&P as well.

Polarization dependent loss (PDL)

Optical signals are generally polarized and the variation in insertion loss with polarization must be determined. This involves determining the maximum and minimum IL vs. polarization for all desired wavelengths, and all combinations of linear and circular polarization. Fortunately this can be done by measuring swept-wavelength IL at a set of four (or optionally six) polarizations, from which any other IL can be calculated. This is known as the Mueller Matrix method.

The setup includes a polarization controller after the TLS, that sets the polarization of the light into the device under test. The 8169A polarization controller does this by sequentially setting each polarization for separate TLS sweeps, support by the PFL software. And now the new N7786B rapidly switches polarization and monitors the SOP and power so PDL can even be measured in one wavelength sweep. This innovative method and calculations such as resolution of TE/TM spectra and determination of polarization dependent wavelength are provided in the N7700A PDL routine.

Dispersion (PMD and CD)

At high data rates, like 10 Gb/s and faster, the variations in time required for parts of the signal to pass through the network causes data pulses to broaden. The way this timing, group delay (GD), varies is called dispersion.

The dependence of GD on polarization is called polarization mode dispersion (PMD) and described by differential group delay (DGD) spectra, the difference between the GD for the fastest and slowest polarizations in the component. This too can be measured with swept wavelength at a set of polarizations, but also requires a polarization analyzer as a receiver. This method is called Jones Matrix Eigenanalysis and is supported by the N7788B component analyzer together with a TLS. This system measures single-channel DGD, PDL, IL and other advanced parameters does this with a single wavelength sweep for optimum stability and speed, using the N7700A Polarization Navigator.

Finally the chromatic dispersion (CD) is the variation of GD itself vs. wavelength and is an important property of optical fiber and especially wavelength-selective components. Measuring this accurately and with sufficient wavelength resolution is achieved with the modulation phase shift (MPS) method, where the TLS signal is amplitude modulated and the variation in phase shift vs. wavelength of the signal through the component is determined. The 86038B Photonic Dispersion and Loss Analyzer uses an enhanced polarization-dependent implementation of MPS with adjustable frequency between 10 MHz and 2.5 GHz to optimize the wavelength resolution and accuracy. This setup then provides spectra for GD, CD, DGD, PDL, IL and other parameters.



Making Transient Optical Power Measurements with the N7744A and N7745A Multiport Optical Power Meter

Measuring optical power level changes, to determine fiberoptic switching times or to observe transient fluctuations from fiber movement or network reconfiguration, goes beyond the design of most fiberoptic power meters. These instruments are generally designed for calibrated determination of optical power levels that are constant or change in synchronization with other instruments. The typical sample rates like 10 kHz, data capacity of perhaps 100,000 samples, and data transfer speed to the controller are often insufficient for general time-dependent measurements. Instead alternative setups, like a fast optical-to-electrical converter combined with an oscilloscope, have been used and described in standards. These often sacrifice optical power calibration, involve additional integration effort, and are likely implemented with an over-dimensioned scope bandwidth.

The N7744A 4-port and N7745A 8-port optical power meters now offer the performance to make these measurements with a small self-contained programmable instrument that is used together with a controller computer. These power meters accurately log optical power at selectable sample rates up to 1 MHz, store up to 2 million samples per port, allow fast data transfer via USB or LAN and support simultaneous measurement and data transfer for continuous power monitoring without interruption.

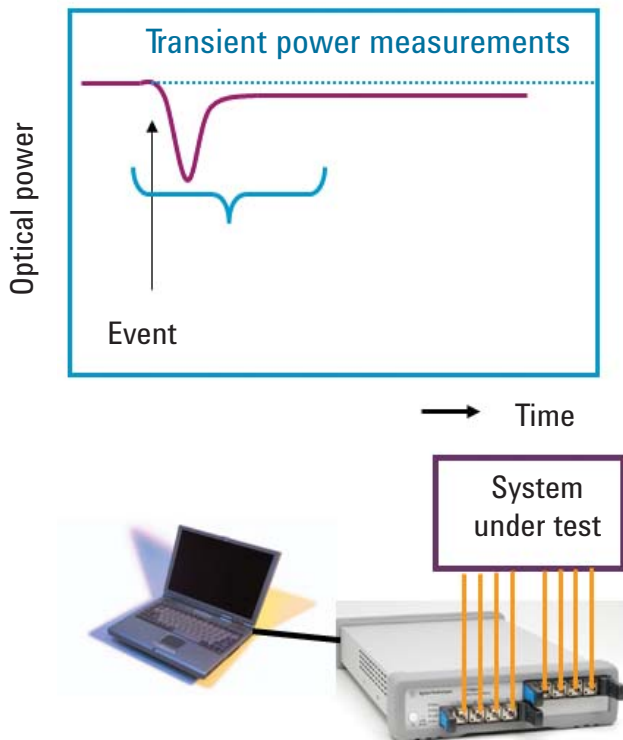

Logging Functionality Basics

The measurement of time-dependent signals is realized with the easy-to-use logging function of the optical power meters. The logging function is set up by choosing the number of logging samples, N , and the averaging time of each sample, t . The logging measurement is then started with a programming command or an electrical trigger. The instrument can be configured to make the complete logging measurement of N samples or individual samples when triggered. For logging time-dependence, the measurement will usually be configured for logging all samples without pause over a total time Nt .

For completeness, note that the instruments also have a stability function that performs similarly, but with a programmable dwell time between samples. This is used for measuring longer term changes in optical power, as for source stability tests, and is not discussed here further.

The N7744A and N7745A multiport power meters, MPPM, can perform this logging simultaneously on optical signals from up to 8 fibers. The averaging time can be chosen between 1 μ s and 10 s, and up to 1 million samples can be taken. During the logging, a wide dynamic range can be recorded, exceeding 60 dB for averaging times of 100 μ s or more, and the power range maximum can be chosen between -30 dBm and $+10$ dBm in 10 dB steps. The MPPM can also be configured to begin a new logging measurement of N samples as soon as the previous measurement finishes. The existing results can be uploaded to the controller computer during the new measurement. This set of functionality provides two methods for making transient measurements, which we label here as triggered logging and continuous logging methods.

Triggered logging is used to measure a fixed number of samples, starting from a time chosen by software or an electrical signal to synchronize with the event to be measured. This is most useful when the timing of the event to be measured is also controlled, as for setting a switch or shutter, changing an attenuator, or blocking an input signal to an amplifier or ROADM (reconfigurable add/drop multiplexer). Since 1 million samples can be stored per port, a single logging measurement is usually sufficient. The multiple ports of the instrument make it easy to watch, for example, all output ports of a switch during reconfiguration. Measurements like described in the IEC standard 61300-3-21 for switching time and bounce time or transient characterization of optical amplifiers can be accomplished with this method.

Continuous logging is especially useful for recording events with unpredictable timing as well as for keeping a very large number of samples. A typical application would be the measurement described in IEC 61300-3-28 for transient loss, where the power from fibers is monitored for change due to mechanical disturbances. This method can be programmed using the same logging function mentioned above, with the extension that the complete logging sequence is repeated multiple times. For such real-time processing while data is being gathered, multi-threaded programming is useful to avoid interruption of the data stream, as now available in Agilent VEE 9.0 and higher.

For a more detailed description refer to: Application Note 5990-3710EN: Making Transient Optical Power Measurements with the N7744A and N7745A Multiport Optical Power Meter



Modular and Multi-Channel Test and Measurement Platform for Optical Components and Optical Networks

Flexible

Free combination of instruments for the best fit to each application

Scalable

The right form factor for each setup in R&D and manufacturing for single-port and multiport applications

Efficient

Plug&Play drivers and the Photonic Application Suite software from Agilent provide a variety of application functions for increased measurement performance

Fast

Modules and controllers optimized for high test speed and data throughput

Ergonomic

Comfortable color, high contrast displays for enhanced stand-alone benchtop usability

This family of optical test instruments and modules covers all kind of fiberoptic test capability from tunable and fixed sources via signal and path control to a broad range of optical power measurement modules and instruments. Different form factors and performance classes allow an easy adaptation to any test need and support both manual use and remote control via LAN, GPIB and USB. A common remote language lets you control all test module categories with the same set of commands.



The Agilent 8163B – Modular Stimulus-Response Solutions with Excellent Performance

The two-slots Agilent 8163B lightwave multimeter is one of the basic measurement tools in the fiber optics industry. Its modularity and compact format makes it flexible enough to meet changing measurement needs, whether measuring optical power and loss with laser and power meter modules or using attenuator and switch as signal conditioning.

The Agilent 8164B - The Platform for Testing Optical Components



The Agilent 8164B lightwave measurement system supports a wide range of tunable laser modules together with capacity for up to 8 power meters in one box, for high resolution spectral testing of passive components. Its LAN and GPIB ports provide connectivity for remote control that can be utilized for system automation, supported with Agilent's software suite. For easy standalone operation of the 8164B, the large display and comfortable controls make this a great benchtop tool.

The Agilent 8163B and 8164B mainframes and optical modules have commonly used built-in applications for quick manual testing without programming:

- Passive component test (PACT) — measure spectral insertion loss with a tunable laser module and one or more power meter module
- Return loss/loss — measure the return loss and insertion loss of your devices with the 81613A return loss module and a power meter module (8163B only)
- Stability — check the long term power stability of the device under test with a source module and a power meter module or power head
- Logging — perform statistical analysis on the power readings of your device

The Agilent 77-Series of Multichannel Power Meters, Attenuators and Tunable Sources

NEW

The characterization of multiport optical devices or parallel testing of optical devices demands a new set of optical test equipment, which provides cost-effectiveness, high speed measurement throughput and parallel data acquisition and data aggregation. Agilent's 77-Series expands the optical test and measurement family to address this kind of test demand.

The instruments are controlled via a Graphical User Interface (GUI) on your PC or laptop computer, which eliminates the cost of multiple instrument displays, controls and the related electronics. The GUI let's you monitor and control the multiple channels at a glance and gives a quick status information. Powerful full functionality is available by remote control via USB, LAN or GPIB.





The N7700A Photonic Application Suite

- **Display and overlay of traces from multiple channels and multiple measurement files**
- **Scale switching between wavelength and frequency**
- **Display of tabular analysis**
- **Smoothing, markers and zooming**
- **File loading, saving and data export**
- **Direct launching of Excel and Matlab with data**

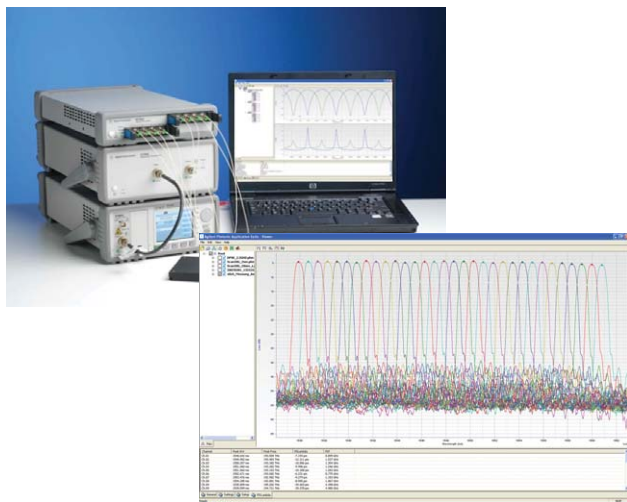

The N7700A Photonic Application Suite is a modular software platform for fast, easy and advanced characterization and analysis of optical components and signals. This suite is widely distributed with instruments and from the Agilent website and can be installed on PCs to control instruments and to process and analyze measurement data.

The freely-distributed main package of the N7700A Photonic Application Suite provides a powerful File Viewer program that allows viewing and analyzing measurement data. It has been designed for sharing measurement results throughout entire development teams or manufacturing groups.

The File Viewer uses the same N77xx Windows-based graphical user interface that is used in the measurement engine packages. The controls for this interface can also be built into customized programs for automated data display.

For performing measurement tasks, an increasing range of application packages are available. Some basic ones are available free for use with the instruments. Licenses can be purchased for more advanced packages. All packages can be downloaded and used immediately for a 14 day trial period and 60-day evaluation licenses can also be generated automatically from the Agilent web site for extended consideration.

Insertion Loss

The Insertion Loss measurement package performs very accurate swept-wavelength insertion loss measurements using one of Agilent's tunable laser sources along with optical power meters. No license required.

Fast IL/PDL measurement

The Fast IL/PDL measurement package makes rapid and very accurate measurements of spectral insertion loss and polarization dependent loss (PDL) characteristics of multiport optical components. The new single sweep Mueller Matrix method provides speed and immunity from vibrations and noise. Measurements including multiple lasers for wider wavelength coverage and return loss module are now also supported. In addition to the measured IL and PDL traces, the Mueller Matrix data can be exported and analyzed to provide the polarization resolved IL traces for the device axes (TE/TM).

License available for purchase as N7700A-100.

Filter Analysis

The Filter Analysis package provides extended post-processing of measurements from the IL/PDL and IL measurement packages for analysis of narrow-band components like filters and multiplexers. Analysis parameters include peak and center wavelength, wavelength offset from ITU grid, IL at ITU wavelength and center wavelength, bandwidth and channel isolation from adjacent and non-adjacent channels. From the TE & TM traces of the IL/PDL engine, the polarization dependent frequency shift (PDF or PDA) of channels in filters, interleavers or phase demodulators can also be determined. A convenient peak search function is also included.

License available for purchase as N7700A-101.

Polarization Navigator

The Polarization Navigator package provides all the tools needed for your work with N778x polarization analysis and control instruments: measurement of Stokes parameters and degree of polarization (DOP); representation on the Poincaré sphere or time dependent long term monitoring, spike analysis, etc. Various functions for control, switching and scrambling the polarization of optical signals are also provided. No license required for use with N778x instruments.

N4150A Agilent Photonic Foundation Library

The N4150A Agilent Photonic Foundation Library is well known as the established software for photonic engineers. This library is also integrated with the N7700A Photonic Application Suite and programs using this library can also use the new automation controls for display.

License available for purchase as N7700A-200.



- Complete wavelength coverage from 1260 nm to 1640 nm
- Low SSE output for high dynamic range
- Built-in wavelength meter for high wavelength accuracy
- Sweep speeds up to 80 nm/s to reduce test times
- No compromise of measurement accuracy for sweep speed



Tuning Range from 1260 nm to 1640 nm

Agilent offers a family of tunable laser sources to cover the wavelength range of 1260 nm to 1640 nm. Whether you are measuring Dense Wavelength Division Multiplexing (DWDM) devices or a WDM device, such as an LX4 component for 10 Gigabit Ethernet, Agilent has a laser to fit your testing needs.

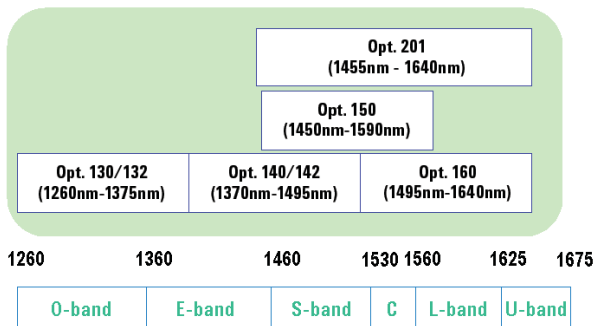

Agilent TLS portfolio

It Sweeps as Precisely as it Steps

As manufacturing yields become more demanding it is critical for your test instruments to have optimal performance for any measurement condition. The 81600B offers several sweep speeds up to 80 nm/s without compromising measurement accuracy. In contrast to other lasers, the 81600B sweeps with the same precision as it steps; without the use of an external wavelength-tracking filter. No compromise on sweep speed.

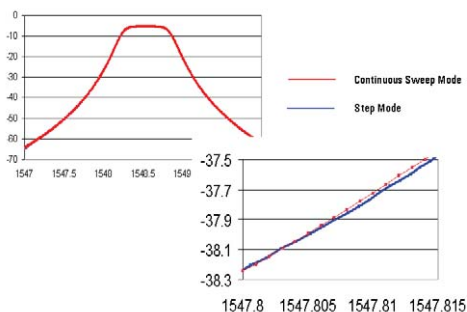

No compromise on sweep speed

Advantage of Using Suppressed Laser Noise (low SSE)

Source Spontaneous Emission (SSE), the sum of all spontaneous emissions inside the laser diode of the tunable laser, is broadband light output in addition to the monochromatic laser line. This emission limits the noise floor of the tunable laser, which, in turn, limits the dynamic range of your measurements. The Agilent tunable laser source offers a high signal to source spontaneous emission ratio. For you, this means more dynamic range to enable your measurements to completely characterize DWDM devices with high channel isolation.

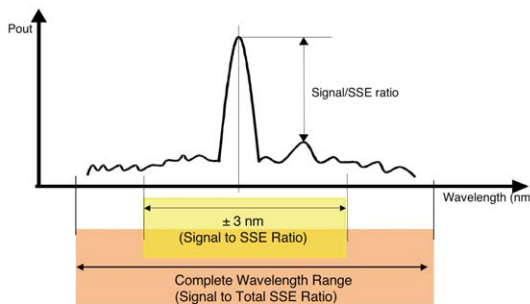

Agilent laser noise definition

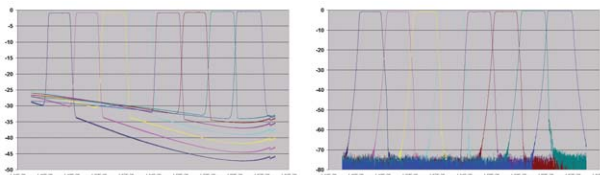

Output 2: high power Output 1: low SSE

Reduce Cost of Test

For DWDM components, high wavelength accuracy and dynamic range are most important. For CWDM components, a wide wavelength range, high power stability, dynamic range and low cost targets are key. Agilent's state-of-the-art tunable lasers meet the demanding requirements of high tech optical manufacturing facilities with fast sweep speed, high wavelength accuracy and power stability. This will reduce your test time while increasing your throughput, hence, reducing the cost of test in manufacturing to give you the competitive advantage.

Agilent 81600B Tunable Laser Modules (cont.)



www.agilent.com/find/tls

	132/142	130/140/150/160	201
Output Power, peak (typ)	≥ +9/+8.5 dBm	Output 1: ≥ -4/-4.5/-1/-2 dBm Output 2: ≥ +5/+5.5/+7/+7 dBm	Output 1: ≥ +3 dBm Output 2: ≥ +9 dBm
Signal to SSE ratio	≥ 45/42 dB/nm	Output 1: ≥ 63/63/65/64 dB/nm Output 2: ≥ 42/42/45/45 dB/nm	Output 1: ≥ 70 dB/nm Output 2: ≥ 48 dB/nm
Signal to total SSE ratio	≥ 28 dB	Output 1: > 58/60/60/59 dB Output 2: ≥ 26/28/30/27dB (typ)	Output 1: ≥ 65 dB Output 2: ≥ 30 dB (typ)
Wavelength Stability (typ)		≤ ± 1 pm (24h)	
Power Repeatability		± 0.003 dB	
RIN	-145 dB/Hz typ.	-140 dB/Hz typ.	-145 dB/Hz (1520-1610 nm)
Wavelength Repeatability		± 0.8 pm, typ ± 0.5 pm	

Parameter	Common to all 81600B options			
	Stepped Mode	Continuous sweep mode (typ.)		
		at 5 nm/s	at 40 nm/s	at 80 nm/s
Abs. wavelength accuracy	± 10 pm, typ. ± 3.6 pm	± 4.0 pm	± 4.6 pm	± 6.1 pm
Rel. wavelength accuracy	± 5 pm, typ. ± 2 pm	± 2.4 pm	± 2.8 pm	± 4.0 pm
Wavelength repeatability	± 0.8 pm typ. ± 0.5 pm	± 0.3 pm	± 0.4 pm	± 0.7 pm
Dyn. power reproducibility		± 0.005 dB	± 0.01 dB	± 0.015 dB
Dyn. Rel. power flatness		± 0.01 dB	± 0.02 dB	± 0.04 dB
Wavelength resolution			0.1 pm, 12.5 MHz at 1550 nm	
Maximum sweep speed			80 nm/s	
Linewidth (coherence control off)			100 kHz	
Power stability			± 0.01 dB, 1 hour typ. ± 0.03 dB, 24 hour	
Power linearity			Output 1: ± 0.1 dB Output 2: ± 0.1 dB (± 0.3 dB in attenuation mode)	
Power flatness versus wavelength			Output 1: ± 0.25 dB, typ. ± 0.1 dB Output 2: ± 0.3 dB, typ ± 0.15 dB	



- **Modular design for multichannel platform**
- **Up to 110 nm coverage in one module**
- **Device characterization at high power levels up to +14 dBm**
- **SBS suppression feature enables high launch power**
- **Excellent power and wavelength repeatability**



High Power Compact Tunable Lasers for S-, C- and L-band

The Agilent 81940A and 81980A compact tunable laser sources supply an output power of up to +13dBm, and cover a total wavelength range of 110nm, either in the S+C-band with the high power in C-band (81980A), or in the C+L-band with the high power in the L-band (81940A). Both lasers are continuously tunable and support swept-wavelength applications like passive component testing.

The Agilent 81950A compact tunable laser source is an ideal source for loading DWDM systems and EDFAs or for static operation in applications where step tuning is appropriate. It supports a fine tuning range of +/-6 GHz with output power active.

Device Characterization at High Power Levels

The high optical output power of the 819xA tunable lasers enhances test stations for optical amplifier, active components and broadband passive optical components. It helps overcome losses in test setups or in the device under test itself. Thus, engineers can test optical amplifiers such as EDFAs, Raman amplifiers, SOAs and EDWAs to their limits. These tunable lasers provide the high power required to speed the development of innovative devices by enabling the test and measurement of nonlinear effects.

SBS Suppression Feature Enables High Launch Power

The new SBS-suppression feature prevents the reflection of light induced by Stimulated Brillouin Scattering (SBS). It enables the launch of the high power into long fibers without intensity modulation.



Compact tunable laser source with dual power meter in one box

Coherence Control Reduces Interference-Induced Power Fluctuations

A high-frequency modulation function is used to increase the effective linewidth to reduce power fluctuations caused by coherent interference effects. The modulation pattern is optimized for stable power measurements even in the presence of reflections.

Internal Modulation

The internal modulation feature enables an efficient and simple time-domain extinction (TDE) method for Erbium-based optical amplifier test when used together with the external gating feature of the Agilent 86146B. It also supports the transient testing of optical amplifiers by simulating channel add / drop events.

Cost Effective Passive Component Test

The Agilent 81940A and 81980A compact tunable laser sources provide excellent wavelength and power accuracies to enable reliable swept wavelength measurement for passive component test in a cost effective way. The built-in wavelength meter with a closed feedback loop for enhanced wavelength accuracy allows dynamic wavelength logging in continuous sweep mode, supported by the 81940A and 81980A. The integrated dynamic power control loop guarantees highly repeatable measurements.

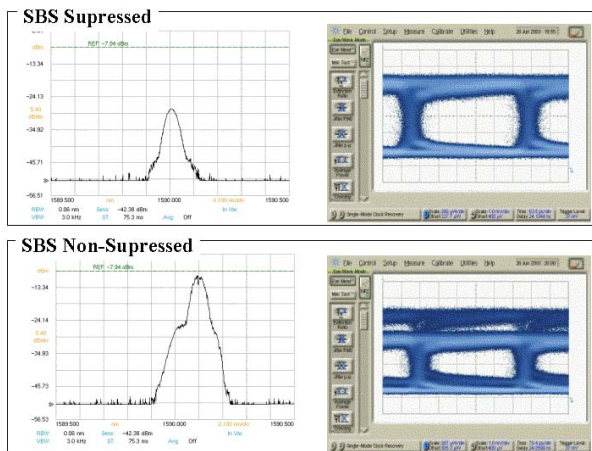

Back-scattered light from in long fibers with and without SBS suppression. The top curve shows the Rayleigh scattered signal, while the lower spectrum is dominated by wavelength-shifted Brillouin scattering.

Agilent 8198xA, 8194xA and 81950A Compact Tunable Laser Sources (cont.)



www.agilent.com/find/tls



81980A and 81989A Compact Tunable Laser Source, 1465 nm to 1575 nm
 81940A and 81949A Compact Tunable Laser Source, 1520 nm to 1630 nm
 81950A Compact Tunable Laser Source (C- and L-band options)

	Agilent 81980A, 81940A	Agilent 81950A
Wavelength Range	1465 nm to 1575 nm (81980A) 1520 nm to 1630 nm (81940A)	1527.6 nm to 1565.50 nm (196.25 to 191.50 THz, 81950A-210) 1570.01 nm to 1608.76 nm (190.95 to 186.35 THz, 81950A-201)
Wavelength Resolution	1 pm, 125 MHz at 1550 nm	Typical 100 MHz, 0.8 pm at 1550 nm
Grid Spacing		50 GHz
Mode-hop Free Tuning Range	Full wavelength range	
Maximum Tuning Speed	50 nm/s	< 30 s (including power stabilization)
Fine Tuning Range / Resolution		Typical ± 6 GHz / Typical 1 MHz
Absolute Wavelength Accuracy	± 20 pm	± 22 pm (± 2.5 GHz)
Relative Wavelength Accuracy	± 10 pm, typ. ± 5 pm	± 12 pm (± 1.5 GHz)
Wavelength Repeatability	± 2.5 pm, typ. ± 1 pm	Typical ± 2.5 pm (± 0.3 GHz)
Wavelength Stability (typ., over 24 h) ³	± 25 pm	± 2.5 pm (± 0.3 GHz), 24 hours
Linewidth (typ.), Coherence Control Off	100 kHz	100 kHz
Effective Linewidth (typ.), Coherence Control On ¹	> 50 MHz for 1525 nm to 1575 nm (81980A) > 50 MHz for 1570 nm to 1620 nm (81940A)	0 to 1 GHz
Maximum Output Power (continuous power during tuning)	> +14.5 dBm peak $\geq +13$ dBm for 1525 nm to 1575 nm (81980A) $\geq +13$ dBm for 1570 nm to 1620 nm (81940A) $\geq +10$ dBm for 1465 nm to 1575 nm (81980A) $\geq +10$ dBm for 1520 nm to 1630 nm (81940A)	+13.5 dBm (typical +15 dBm)
Minimum Output Power	+6 dBm	
Power Linearity (typ.)	± 0.1 dB	
Power Stability ³	± 0.01 dB over 1 hour typ. ± 0.0075 dB over 1 hour typ. ± 0.03 dB over 24 hours	Typical ± 0.03 dB over 24 hours ^[2]
Power Flatness Versus Wavelength	± 0.3 dB, typ. ± 0.15 dB	Typical ± 0.2 dB (full wavelength range)
Power Repeatability (typ.)	± 10 mdB	± 0.08 dB ^[3]
Side-mode Suppression Ratio (typ.) ¹	≥ 50 dB	50 dB
Signal to Source Spontaneous Emission Ratio ²	≥ 45 dB 48 dB/nm for 1525 nm to 1575 nm (81980A) 48 dB/nm for 1570 nm to 1620 nm (81940A)	Typical 50 dB/1 nm ¹ Typical 60 dB/0.1 nm
Signal to Total Source Spontaneous Emission Ratio (typ.) ¹	≥ 25 dB ≥ 30 dB for 1525 nm to 1575 nm (81980A) ≥ 30 dB for 1570 nm to 1620 nm (81940A)	
Relative Intensity Noise (RIN) (typ.) ¹	-145 dB/Hz	-145 dB/Hz 1 (10 MHz to 40 GHz)
Dimensions (H x W x D)	75 mm x 32 mm x 335 mm	75 mm x 32 mm x 335 mm

[1] At maximum output power as specified per wavelength range.

[2] Value for 1 nm resolution bandwidth.

[3] At constant temperature ± 0.5 K.

Ordering information

8163B or 8164B	Lightwave Measurement System (Mainframe)
81980A	Compact Tunable Laser Source C-band, 1465 to 1575 nm, step and sweep mode
81950A-210	Compact Tunable Laser Source C-band, 1465 to 1575 nm, step mode
81940A	Compact Tunable Laser Source L-band, 1520 to 1630 nm, step and sweep mode
81950A-201	Compact Tunable Laser Source L-band, 1520 to 1630 nm, step mode

* All tunable lasers must be ordered with one connector option.

071 for PMF, straight output

072 for PMF, angled output

* One Agilent 81000xl-series connector interface is required



NEW

N7711A, N7714A Tunable Laser Sources

- Compact instrument format with one or four ports per unit on one-half rack-unit width and one-unit height;
- Flexible configuration of four-port model between C- and L-band channels (N7714A);
- Adjustable to any wavelength grid (ITU-T 100 GHz, 50 GHz, 25 GHz, and arbitrary grids);
- Narrow linewidth less than 100 kHz and offset-grid tuning greater than ± 6 GHz ideally suited for coherent mixing applications and new complex modulation formats; and
- Up to +15 dBm output power, with 8 dB power adjustment range.
- Polarization maintaining fiber output.

The new Agilent N7711A and N7714A tunable lasers are single-port and four-port sources, available with C-band or L-band wavelength coverage. The narrow linewidth and offset grid fine-tuning capability of the N7711A and N7714A make them ideal sources for realistic loading of the latest transmission systems.



N7711A one-port Tunable Laser Source



N7714A four-port Tunable Laser Source

The N7711A and N7714A tunable laser sources are step-tunable within any frequency grid in the C-band (1527.60 to 1565.50 nm; 196.25 to 191.50 THz) or L-band (1570.01 to 1608.76 nm; 190.95 to 186.35 THz). Their output power of up to +15 dBm and a linewidth under 100 kHz are ideal to emulate state-of-the-art DWDM transmitters. SBS suppression can be activated on demand to avoid stimulated Brillouin scattering.

Tuning Modes that Fit Every Application

Each individual laser in the N7711A and N7714A features the same tuning modes as the 81950A: in channel setting mode, the source wavelength, (or frequency, respectively) is determined by the chosen channel index, zero frequency and grid spacing; ITU-T standard grids are possible as well as custom grids. In wavelength setting mode the laser is tunable to any wavelength point within its range, just like any other Agilent tunable lasers. In both modes, each laser channel operates independently and can be fine-tuned by ± 6 GHz with output power active.

The 77-Viewer: An easy-to-use graphical user interface

The 77's Window's based graphical user interface offers flexible and extensive control of the instrument

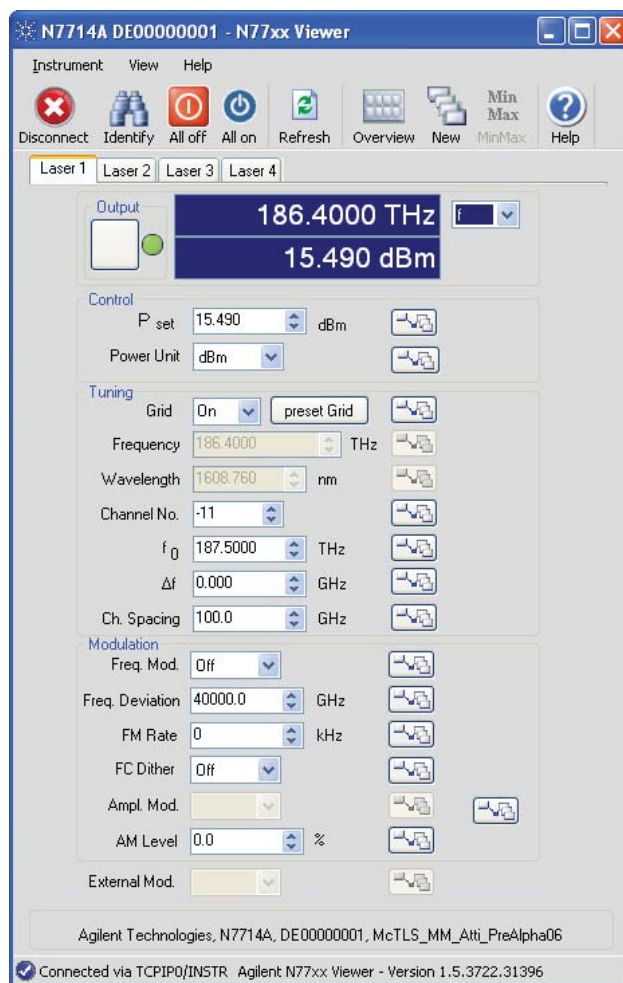

Agilent N7711A and N7714A Multiport Tunable Laser Source



www.agilent.com/find/tls

Technical Specifications

Specifications apply to wavelengths on the 50 GHz ITU-T grid, after warm up.

N7711A and N7714A		
Wavelength	Options #210, #222, #240	Options #201, #222, #204
Wavelength range	1527.60 to 1565.50 nm (196.25 to 191.50 THz)	1570.01 to 1608.76 nm (190.95 to 186.35 THz)
Fine tuning range	typ. \pm 6 GHz	
Fine tuning resolution	typ. 1 MHz	
Absolute wavelength accuracy	\pm 22 pm (\pm 2.5 GHz)	
Relative wavelength accuracy	\pm 12 pm (\pm 1.5 GHz)	
Wavelength repeatability	typ. \pm 2.5 pm (\pm 0.3 GHz)	
Wavelength stability	typ. \pm 2.5 pm (\pm 0.3 GHz), 24 hours	
Tuning time including power stabilization	typ. < 30 s	
Optical Power		
Max. Output Power	+13.5 dBm typ. +15 dBm	
Power Stability	typ. \pm 0.03 dB over 24 hours	
Power Flatness	typ. \pm 0.2 dB (full wavelength range)	
Power Repeatability	typ. \pm 0.08 dB	
Spectral		
Linewidth	typ. < 100 kHz (SBS suppression off)	
Side Mode Suppression Ratio (SMSR)	typ. 50 dB	
Source Spontaneous Emission (SSE)	typ. 50 dB/ 1 nm typ. 60 dB/ 0.1 nm	
Relative Intensity Noise (RIN)	typ. -145 dB/Hz (10 MHz to 40 GHz)	

Non-warranted Performance Characteristics

N7711A and N7714A	
Grid spacing	100, 50, 25 GHz or arbitrary grid
Output Power	
Power Attenuation Range	8 dB
Power Setting Resolution	0.1 dB
Residual Output Power (shutter closed)	-45 dBm
Stimulated Brillouin Scattering	
SBS suppression FM p-p modulation range	0 to 1 GHz
SBS suppression dither frequency	20.8 kHz



The Agilent 81663A high power DFB laser source modules are best suited for multiple fixed-wavelength test applications, like PON component test.

- **Center wavelengths: 1310 nm, 1490 nm, 1510 nm, 1550 nm, 1625 nm**
- **Fine tuning capability ± 500 pm**
- **Excellent power and wavelengths stability**
- **Up to 20mW output power**



High Output Power

The Agilent 81663A modules offer +13 dBm output power to overcome power penalties given in today's test setups. Their excellent power and wavelength stability is key for accurate testing of IL and PDL at PON wavelengths and for loading optical amplifiers.

Applications

- Optical amplifier test
- PON component IL & PDL test
- PON Stimulus-response measurement

Testing Optical Amplifiers

A set of DFB lasers is the ideal test load for modern optical amplifiers due to their excellent stability and price versus performance ratio. The sources address the ever increasing demand for higher stimulus power and support the trend towards higher power amplifiers.

DFB Laser Modules for High Channel Count DWDM Systems

DFB laser modules are best suited to address the test requirements of today's DWDM transmission systems. Their fine tuning capability provides flexibility, as is sometimes desired by DWDM submarine systems, and reduced costs for spare grids. The modularity of the lightwave solution platform allows to easily match test setups with the latest requirements of DWDM systems, and leaves room for future expansions and refinements.

Specifications apply to maximum power setting.

	Agilent 81663A Option #131	Agilent 81663A Option #149	Agilent 81663A Option #151	Agilent 81663A Option #155	Agilent 81663A Option #162
Type	CW DFB Laser with built-in isolator				
Center Wavelength ^{[1][2]}	1310 nm \pm 5 nm	1490 nm \pm 3 nm	1510 nm \pm 3 nm	1550 nm \pm 3 nm	1625 nm \pm 3 nm
Tuning Range	typ. $> \pm 500$ pm				
• Display Resolution	10 pm				
• Repeatability ^[4]	± 5 pm (typ. ± 2 pm)				
• Stability (15min.) ^{[3][4]}	± 5 pm (typ ± 2 pm)				
• Stability (24h) ^{[3][4]}	typ. ± 5 pm				
Fiber type	Panda PMF 9 / 125 mm				
Output Connector ^[6]	Compatible to angled contact APC, ASC, DIN47256/4108				
Power	typ. $> +13$ dBm (20 mW)				
• Max. Output ^[5]	typ. ± 0.003 dB				
• CW Stability (15min) ^[4]	typ. ± 0.01 dB				
• CW Stability (24 h) ^{[3][4]}					
Side Mode Suppression Ratio (SMSR) ^[5]	typ. 50 dB				
Polarization Extinction Ratio (PER)	typ. > 20 dB				
Dimensions (H x W x D)	75 mm x 32 mm x 335 mm (2.8" x 1.3" x 13.2")				
Weight	0.5 kg				
Recalibration Period	2 year				
Operating Temperature	15°C to 35 °C				
Warm-up time ^[3]	60 min				

[1] Center wavelength is shown on display as default.

[2] Via GPIB tuning resolution < 10 pm.

[3] If previously stored at the same temperature 20 min.

[4] Controlled environment DT = ± 1 °C.

[5] At maximum power setting and default wavelength at the end of a 2 m SM patchcord.

[6] Connector interface not included.



- **SMF with 1310nm, 1550nm or 1310/1550nm and MMF with 850nm**
- **Selectable 1mW or 20mW output power**
- **Excellent CW power stability of $\pm 0.005\text{dB}$ (15 min.)**
- **Stable test of patchcords, couplers and connectors**



The Agilent Fabry-Perot laser sources are available as single or dual wavelength sources, are insensitive to back reflections, and are stabilized for short and long term applications.

Flexible Application Fit

Agilent 8165xA Fabry-Perot laser sources are a family of plug-in

modules for Agilent's lightwave solution platform and offer ideal power and loss characterization of optical components and fibers with wavelengths at 850 nm, 1310 nm and 1550 nm, mainly used in optical telecommunication including today's fiber to the home (FTTH) and short reach applications such as Fibre Channel and Gigabit Ethernet.

Ideal Solution for IL, RL and PDL Tests

Combination of Agilent's Fabry-Perot laser source and wide variety of power meters (or optical heads) provides the basic setup for insertion loss (IL) characterization. Simple front panel operation together with a power meter immediately show results of IL. Agilent's 8161xA return loss module can utilize an external laser source such as a Fabry-Perot laser to set up a return loss (RL) test. Adding the Agilent 8169A or N7786B polarization controller enables testing of the polarization properties of optical components.

850 nm Source

For 850nm, the special 81655A Option E03 is also offered with 50/125 μm multimode output.

Ease of Manual Operation

The test environment is at the same time simple and works with small footprint compact. Manual manufacturing operation on the work-bench requires a friendly operating environment which allows users to operate without instrument training. Mainframe's built-in applications including stability, logging and PACT provide an application-fit environment for instrument operation.

Standard modules, 0 dBm / High power modules, 13 dBm

	Agilent 81650A / Agilent 81655A	Agilent 81651A / Agilent 81656A	Agilent 81654A / Agilent 81657A
Type		Fabry-Perot Laser	
Center wavelength ^[1]	1310 nm \pm 15 nm	1550 nm \pm 15 nm	1310/1550nm \pm 15 nm
Fiber type		single-mode 9/125mm	
Spectral bandwidth (rms) ^{[1] [2]}	< 3.5 nm (standard) < 5.5 nm (high power)	< 4.5 nm (standard) < 7.5 nm (high power)	< 3.5nm/ 4.5nm (standard) < 5.5 nm/7.5 nm (high power)
Output power		> 0 dBm (1mW) (standard) > +13 dBm (20 mW) (high power)	
CW power stability ^{[3] [4]}		< ± 0.005 dB typ. < ± 0.003 dB with coherence control active typ. ± 0.03 dB typ ± 0.003 dB	
Dimensions (H x W x D)		75 mm x 32 mm x 335 mm (2.8" x 1.3" x 13.2")	
Weight		0.5 kg	
Recalibration period		2 years	
Operating temperature		0 °C to 45 °C	
Humidity		Non condensing	
Warm-up time		60 minutes ^[3]	

[1] Central wavelength is shown on display

[2] rms: root mean square

[3] Warm-up time 20 min, if previously stored at the same temperature.

[4] Controlled environment (T = ± 1 °C).

Supplementary performance characteristics:

Internal digital modulation mode:

270 Hz, 330 Hz, 1 kHz, 2 kHz and free selection 200 Hz to 10 kHz.

All output signals are pulse shaped, duty cycle 50 %.

Internal coherence control for linewidth broadening

Output attenuation:

The output power of all source modules can be attenuated from 0 dB to 6 dB in steps of 0.1 dB.



- **Patented 4-port optical connector interface for FC, SC, LC, MU and bare-fiber**
- **Storage of up to 1 million power values per channel for high speed measurement data acquisition and transfer**
- **Short minimum averaging time of 1 μ s for high time resolution and transient power measurements**
- **LAN, USB and GPIB programming interfaces**
- **High dynamic range with high bandwidth for accurate high-speed spectra**
- **Code compatibility to Agilent's Lightwave Measurement System platform**



Agilent N7745A Multiport Power Meter with Quad-Adapter Connector Interfaces N7740ZI, N7740FI, N7740BI, N7740KI (left to right)

Up to Eight Power Meter Channels in a Small Package

Agilent's new N7744A and N7745A optical power meters with four or eight power-sensor channels provide manufacturing customers with increased throughput and operational efficiency to meet today's challenges in manufacturing.

Agilent N7744A, N7745A

Sensor element	InGaAs
Wavelength range	1250 nm to 1650 nm
Specification wavelength range	1250 nm to 1625 nm (if not stated differently)
Power range	-80 dBm to +10 dBm
Maximum safe power	+16 dBm
Data logging capability	1 million measurement points per port
Averaging time	1 μ s to 10 s
Applicable fiber type	Standard SM and MM $\leq 62.5 \mu$ m core size, NA ≤ 0.24
Uncertainty at reference conditions	$\pm 2.5\%$
Total uncertainty	$\pm 4.5\%$
Relative port to port uncertainty	typ. ± 0.05 dB
Linearity at (23 \pm 5°C) over operating temperature	± 0.02 dB ± 3 pW ± 0.04 dB ± 5 pW
Polarization dependent responsivity	$< \pm 0.015$ dB (1520 nm to 1580 nm) typ. $< \pm 0.01$ dB (1250 nm to 1580 nm)
Noise peak-to-peak (dark)	< 7 pW (1 s averaging time, 300 s observation time)
Return loss	> 50 dB (1520nm to 1580nm) typ. > 57 dB (1280 nm to 1580 nm)
Operating temperature	+5 °C to +40 °C
Operating humidity	15% to 95%, non-condensing
Storage conditions	-40 °C to +70 °C
Warm-up time	20 min.
Recommended recalibration period	24 months
Dimensions (H x W x D)	372 mm \times 212 mm \times 43 mm
Weight	3 kg (6 lb)

Designed for Optical Multiport Applications

Designed for characterizing optical multiport components, these optical power meters offer industry-leading solutions for device connectivity, high-speed measurement data acquisition and fast data transfer for postprocessing.

The multiport power meter enables fast measurement solutions for all multiport devices; for example multiplexers, PON splitters, wavelength selective switches (WSS) and ROADMs, as well as compact setups for simultaneous testing of multiple single-port devices.

These power meters are easily integrated with a tunable laser using the N7700A software to make fast IL and PDL measurements.

Continuous Data Logging

Each channel can log up to 1M samples and has an additional 1M buffer. Sampling can be set between 1us and 10s. The buffer allows data upload during measurements for uninterrupted transient power measurement and monitoring.

A Reliable Four-port Optical Connection with a New One-click Quad-Adapter

With this new power meter comes the unprecedented N7740xl fiber connectivity concept, which is a quadruple adapter with a snap-on quick-locking mechanism. The device to be tested can be connected to the quad-adapters in a comfortable ergonomic working position, even while the instrument is measuring another device.

Then the quad-adapters can quickly be snapped on, to provide repeatable high-precision connections. Use of the quad-adapters simplifies aligning connector keys, especially for rack-mounted instruments and makes it easier to connect ports in the desired order, helping to avoid errors and connector damage.

This quad-adapter fits also into Agilent's standard bare fiber connectivity solutions 81000Bx.



- Complete wavelength range, 450 nm to 1800 nm
- Low uncertainty of $\leq \pm 0.8\%$ at reference conditions
- Low PDL of ± 0.005 dB, for polarization sensitive tests
- High single-sweep dynamic range of 55 dB
- High power measurements of up to +40 dBm
- Support of high channel count testing with dual power sensor
- Support of bare-fiber and open-beam applications with a 5 mm detector
- Synchronous measurements with a laser source or external modulation



Wide Variety of Optical Power Sensors and Optical Heads

The superiority of Agilent's stimulus-response test solutions guarantee performance. Agilent has been an industry leader in optical instrumentation since the early 1980s - excellence in laser sources, reliable power sensor modules and large detector optical heads.

The power measurement instruments are available in two formats: self-contained power sensor modules for front-panel optical fiber connection and external power measurement heads for flexible connection positioning, which are connected to the mainframe using the 81618A or 81619A (dual) interface modules. The external beams with a large 5 mm detector are also useful in many free-space optical configurations.

The flexible connector interface system allows the same instrument to be used with many different types of optical connector.

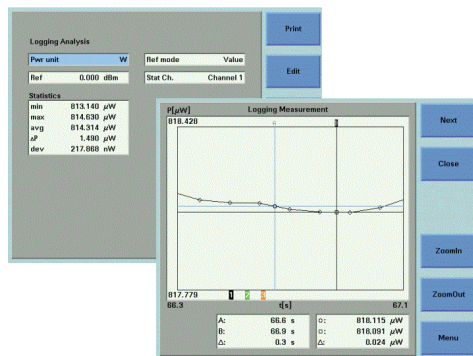

Logging application for flatness and PDL test

Optical Power Sensors

- 81635A: dual-channel sensor, lowest price
- 81634B: most accurate sensor, highest sensitivity
- 81636B: fast power sensor, 100 k points, 25 μ s averaging, higher dynamic range during logging
- 81630B: highest power sensor

Optical Power Heads

- 81623B: Ge head, general purpose, also specified for 850 nm
- 81624B: InGaAs head, highest accuracy
- 81626B: InGaAs head, high power with high relative accuracy
- 81628B: InGaAs head with integrating sphere, highest power and accuracy at high power

Passive Component Test

For multi-channel devices, such as, CWDM and AWG, for R&D or the manufacturing environment, accurate measurements at a minimum cost are in demand. The modular design provides the user with the flexibility to add power meters or mainframes for high channel count or high dynamic range applications. Testing of free space optics, such as, thin film filter (TFF) and waveguide alignment, are easily supported with the optical head. Its 5mm detector and long, moveable reach provides the user with easy handling.

Active Component Test

High power amplifiers and sources are developed today in order to transmit signals over longer distances and to support a high loss environment for complex systems. High power measurements of +40 dBm, can be accomplished without an attenuator, which could add to the measurement uncertainty.

Optical Component Test in the Visible Wavelength Range

For measuring visible and near-infrared light, like used in POS (polymer optical fiber) networks, visible LED's or infrared remote control sources, the new 81623B Option E01 external power head is an ideal solution. It covers the wavelength range from 450 nm to 1020 nm.

Research and Calibration

Low measurement uncertainty of $< \pm 2.5\%$ and low PDL of $< \pm 0.005$ dB

are a couple of the key features found in the Agilent power sensors. All of Agilent's power meter products are NIST and PTB traceable to guarantee precise optical power measurements.

All metrology labs are ISO 17025 certified to meet general requirements for the competence of testing and calibration laboratories.

The instruments can log up to 20k points with sampling times down to 100 μ s, or even 100k points at 25 μ s with the 81636B. These samples can be triggered by the tunable laser for swept-wavelength spectral measurements. Built-in routines are also included for measuring maximum and minimum power, stability over extended time, and offset from an initial measurement value. Results can be displayed in mW, dBm, or dB change.

Agilent 8163xA/B and 8162xB Optical Power Meters



www.agilent.com/find/oct

	Agilent 81635A	Agilent 81634B	Agilent 81630B
Sensor Element	InGaAs (dual)	InGaAs	InGaAs
Wavelength Range	800 nm to 1650 nm	800 nm to 1700 nm	970 nm to 1650 nm
Power Range	-80 dBm to +10 dBm	-110 dBm to +10 dBm	-70 dBm to +28 dBm
Applicable Fiber Type	Standard SM and MM up to 62.5 μ m core size, NA \leq 0.24	Standard SM and MM up to 100 μ m core size, NA \leq 0.3	Standard SM and MM up to 100 μ m core size, NA \leq 0.3
Uncertainty (accuracy) at Reference Conditions	typ. < \pm 3 % (1200 nm to 1630 nm)	\pm 3.5 % (800 nm to 1200 nm) (1000 nm to 1630 nm)	\pm 2.5 % \pm 3.0 % for 1255 nm to 1630 nm at 980 nm \pm 3.5 % (add \pm 0.5% per nm if 980 nm is not the center wavelength) at 1060 nm \pm 4.0 % (add \pm 0.6% per nm if 1060 nm is not the center wavelength)
Total Uncertainty	typ. \pm 5.5% \pm 200 pW (800 nm to 1200 nm) \pm 5% \pm 20 pW (1200 nm to 1630 nm)	\pm 4.5% \pm 0.5 pW (1000 nm to 1630 nm)	\pm 5 % \pm 1.2 nW (1255 nm to 1630 nm) at 980 nm \pm 5.5 % \pm 1.2 nW (add \pm 0.5% per nm if 980 nm is not the center wavelength) at 1060 nm \pm 6.0 % \pm 1.2 nW (add \pm 0.6 % per nm if 1060 nm is not the center wavelength)
Relative Uncertainty			
– due to polarization	typ. < \pm 0.015 dB	< \pm 0.005 dB	< \pm 0.01 dB
– spectral ripple (due to interference)	typ. < \pm 0.015 dB	< \pm 0.005 dB	< \pm 0.005 dB
Linearity (power)	CW -60 dBm to +10 dBm	CW -90 dBm to +10 dBm	CW -50 dBm to +28 dBm (970 nm – 1630 nm)
– at 23°C \pm 5°C	typ. < \pm 0.02 dB (800 nm to 1200 nm) < \pm 0.02 dB (1200 nm to 1630 nm)	< \pm 0.015 dB (1000 nm to 1630 nm)	\leq \pm 0.05 dB
– at operating temp. range	typ. < \pm 0.06 dB (800 nm to 1200 nm) < \pm 0.06 dB (1200 nm to 1630 nm)	< \pm 0.05 dB (1000 nm to 1630 nm)	\leq \pm 0.15 dB
Return Loss	> 40 dB	> 55 dB	> 55 dB
Noise (peak to peak)	typ. < 200 pW (800 nm to 1200 nm) < 20 pW (1200 nm to 1630 nm)	< 0.2 pW (1200 nm to 1630 nm)	< 1.2 nW (1255 nm – 1630 nm)
Averaging Time (minimal)	100 μ s	100 μ s	100 μ s
Analog Output	None	included	included
Maximum safe input power	> +16 dBm	+16 dBm	28.5 dBm
Dimensions (H x W x D)	75 mm x 32 mm x 335 mm (2.8" x 1.3" x 13.2")	75 mm x 32 mm x 335 mm (2.8" x 1.3" x 13.2")	75 mm x 32 mm x 335 mm (2.8" x 1.3" x 13.2")
Weight	0.5 kg	0.5 kg	0.6 kg
Recommended Recalibration Period	2 years	2 years	2 years
Operating Temperature	+10 °C to + 40 °C	0 °C to + 45 °C	0 °C to + 35 °C
Humidity	Non-condensing	Non-condensing	Non-condensing
Warm-up Time	20 min	20 min	20 min
Agilent 81636B			
Sensor Element	InGaAs		
Wavelength Range	1250 nm to 1640 nm		
Power Range	-80 dBm to +10 dBm		
Applicable Fiber Type	Standard SM and MM up to 62.5 μ m core size, NA \leq 0.24		
Uncertainty (accuracy) at Reference Conditions	\pm 3 % (1260 nm to 1630 nm)		
Total Uncertainty	\pm 5% \pm 20 pW (1260 nm to 1630 nm)		
Relative Uncertainty			
– due to polarization	typ. \pm 0.015 dB		
– spectral ripple (due to interference)	typ. \pm 0.015 dB		
Linearity (power)	CW -60 to +10 dBm, (1260 nm to 1630 nm)		
– at 23°C \pm 5°C	< \pm 0.02 dB		
– at operating temperature range	< \pm 0.06 dB		



Agilent 81636B continued	
Return Loss	> 40 dB
Noise (peak to peak)	< 20 pW (1260 nm to 1630 nm)
Averaging Time (minimal)	25 μ s
Dynamic Range at Manual Range Mode	
– at +10 dBm-range	typ. > 55 dB
– at 0 dBm-range	typ. > 55 dB
– at –10 dBm-range	typ. > 52 dB
– at –20 dBm-range	typ. > 45 dB
Noise at Manual Range Mode (peak to peak)	
	CW –60 to +10 dBm, 1260 nm to 1630 nm
– at +10 dBm-range	< 50 nW
– at 0 dBm-range	< 5 nW
– at –10 dBm-range	< 1 nW
– at –20 dBm-range	< 500 pW
Analog Output	Included
Dimensions (H x W x D)	75 mm x 32 mm x 335 mm (2.8" x 1.3" x 13.2")
Weight	0.5 kg
Recommended Recalibration Period	2 years
Operating Temperature	+10 °C to +40 °C
Humidity	Non-condensing
Warm-up Time	20 min

	Agilent 81623B	Agilent 81623B Calibration Option C85/C86	Agilent 81623B Calibration Option C01/C02	Agilent 81623B #E01 (special Silicon Detector)
Applicable Fiber Type Standard Open Beam	SM and MM max 100 μ m core size, NA 0.3; Parallel beam max ϕ 4 mm			
Sensor Element	Ge, ϕ 5 mm			Si, ϕ 5mm
Wavelength Range	750 nm to 1800 nm			450 nm to 1020 nm
Power Range	–80 dBm to +10 dBm			–90 dBm to +10 dBm
Uncertainty at Reference Conditions	$\pm 2.2\%$ (1000 nm to 1650 nm) $\pm 3.0\%$ typ. (800 nm to 1000 nm)	$\pm 2.2\%$ (1000 nm to 1650 nm)	$\pm 1.7\%$ (1000 nm to 1650 nm) $\pm 2.5\%$ (800 nm to 1000 nm)	$\pm 2.2\%$ (600 nm to 1020 nm) ^[1] $\pm 3.0\%$ (800 nm to 1000nm)
Total Uncertainty	$\pm 3.5\% \pm 100$ pW (1000 nm to 1650 nm) $\pm 4.0\%$ typ. ± 250 pW (800 nm to 1000 nm)	$\pm 3.5\% \pm 100$ pW (1000 nm to 1650 nm) $\pm 3.5\% \pm 250$ pW (800 nm to 1000 nm)	$\pm 3.0\% \pm 100$ pW (1000 nm to 1650 nm) $\pm 4.0\%$ typ. ± 250 pW (800 nm to 1000 nm)	typ. $\pm 4\% \pm 0.5$ pW (600 nm to 1020 nm) ^[2]
Relative Uncertainty				
– due to polarization	< ± 0.01 dB (typ. < ± 0.005 dB)			
– spectral ripple (due to interference)	< ± 0.006 dB (typ. < ± 0.003 dB)			
Linearity (power)	(CW –60 dBm to +10 dBm)			
– at 23°C ± 5 °C	< ± 0.025 dB			
– at operating temp. range	< ± 0.05 dB			
Return Loss	> 50 dB, typ. > 55 dB			
Noise (peak to peak)	< 100 pW (1200 nm to 1630 nm) < 400 pW (800 nm to 1200 nm)			typ. < 0.5 pW (700 nm to 900 nm)
Averaging Time (minimal)	100 μ s			
Analog Output	included			
Maximum safe input power	+16 dBm			
Dimensions (H x W x D)	57 mm x 66 mm x 156 mm			
Weight	0.5 kg			0.5 kg
Recommended Recalibration Period	2 years			2 years
Operating Temperature	0°C to 40°C			0°C to 40°C
Humidity	Non-condensing			
Warm-up Time	40 min			20 min

[1] Reference conditions:

- Power level 10 W (–20 dBm), continuous wave (CW)
- Parallel beam, 3 mm spot diameter on the center of the detector
- Ambient temperature 23 °C ± 5 °C
- On day of calibration (add $\pm 0.3\%$ for aging over one year, add $\pm 0.6\%$ over two years)
- Spectral width of source < 10 nm (FWHM)
- Wavelength setting at power sensor must correspond to source wavelength ± 0.4 nm

[2] Operating Conditions:

- Parallel beam, 3mm spot diameter on the center of the detector or connectorized fiber with NA ≤ 0.2 (straight connector)
- Averaging time 1s
- For NA > 0.2: add 1%
- Within one year after calibration, add 0.3% for second year
- Spectral width of source < 10 nm (FWHM)
- Wavelength setting at power sensor must correspond to source wavelength ± 0.4 nm

Agilent 8163xA/B and 8162xB Optical Power Meters (cont.)



www.agilent.com/find/oct

	Agilent 81624B	Agilent 81624B Calibration Option C01/C02	Agilent 81626B	Agilent 81626B Calibration Option C01/C02
Sensor Element		InGaAs, ø 5 mm		InGaAs, ø 5mm
Wavelength Range		800 nm to 1700 nm		850 nm to 1650nm
Power Range		-90 dBm to +10 dBm		-70 to +27 dBm (1250 nm to 1650 nm) -70 to +23 dBm (850 nm to 1650 nm)
Applicable Fiber Type Open Beam		Standard SM and MM max 100 µm core size, NA ≤ 0.3 Parallel beam max ø 4 mm		Standard SM and MM max 100 µm core size, NA ≤ 0.3 Parallel beam max ø 4 mm
Uncertainty at Reference Conditions		± 2.2 % (1000 nm to 1630 nm)	± 1.5 % (970 nm to 1630 nm)	± 3.0 % (950 nm to 1630 nm)
Total Uncertainty		± 3.5% ± 5 pW (970 nm to 1630 nm)	± 2.8% ± 5 pW (950 nm to 1630 nm)	± 5.0% ± 500 pW (950 to 1630 nm)
Relative Uncertainty				
- due to polarization		≤ ± 0.005 dB (typ. ± 0.002 dB)		≤ ± 0.005 dB (typ. ± 0.002 dB)
- spectral ripple (due to interference)		≤ ± 0.005 dB (typ. ≤ ± 0.002 dB)		≤ ± 0.005 dB (typ. < ± 0.002 dB)
Linearity (power)		CW -70 dBm to +10 dBm, 1000 nm to 1630 nm		CW -50 dBm to +27dBm, 950 nm to 1630 nm
- at 23°C ± 5°C		< ± 0.02 dB		< ± 0.04 dB
- at operat. temp. range		< ± 0.05 dB		< ± 0.15 dB
Return Loss typ.		60 dB	>45 dB	>47 dB
Noise (peak to peak)		<5 pW		<500 pW
Averaging Time (min.)		100 µs		100 µs
Analog Output		included		Included
Maximum safe input power		+16 dBm		+23.5 dBm (850-1250 nm) / +27.5 dBm (1250-1650 nm)
Dimensions (H x W x D)		57 mm x 66 mm x 156 mm		57 mm x 66 mm x 156 mm
Weight		0.5 kg		0.5 kg
Recommended Recalibration Period		2 years		2 years
Operating Temperature		0°C to 40°C		0°C to +35°C
Humidity		Non-condensing		Non-condensing
Warm-up Time		40 min		40 min
Agilent 81628B with Integrating Sphere				
Sensor Element	InGaAs			
Wavelength Range	800 nm to 1700 nm			
Power Range	-60 dBm to +40 dBm (800 nm to 1700 nm) For operation higher than 34 dBm ¹			
Damage Power	40.5 dBm			
Applicable Fiber Type / Open Beam	Single mode NA ≤ 0.2, Multimode NA ≤ 0.4 / ø ≤ 3 mm center of sphere			
Uncertainty at Reference Conditions	± 3.0 % (970 nm to 1630 nm)			
Total Uncertainty	(970 nm to 1630 nm)			
≤ 10 dBm	± 4.0% ± 5 nW			
> 10 dBm to ≤ 20 dBm	± 4.5%			
> 20 dBm to ≤ 38 dBm	± 5%			
Relative Uncertainty				
- due to polarization	typ. ≤ ± 0.006 dB			
- due to speckle noise at source linewidth:				
0.1 to 100 pm	typ. < ± 0.02 db			
> 100 pm	typ. < ± 0.002 db			
Linearity (power)	(CW -40 dBm to +38 dBm), (970 nm to 1630 nm)			
≤ 10 dBm	≤ ± 0.03 dB			
> 10 dBm to ≤ 20 dBm	≤ ± 0.06 dB			
> 20 dBm to ≤ 37 dBm	≤ ± 0.09 dB			
> 37 dBm to ≤ 38 dBm	≤ ± 0.10 dB			
	at 23 °C ± 5 °C, for operating temperature range add ± 0.03 dB			
Return Loss	typ. > 75 dB			
Noise (peak to peak)	< 5 nW			
Averaging Time (minimal)	100 µs		Analog Output	Included
Dimensions (H X W X D)	55 mm x 80 mm x 250 mm		Operating Temperature	0 °C to +40 °C
Weight	0.9 kg (without heat sink)		Humidity	Non-condensing
Recommended Recalibration Period	2 years		Warm-up Time	40 min

¹⁾ For optical power higher than 34 dBm the attached heat sink MUST be used! For continuous optical power or average optical power higher than 38 dBm the connector adapters will get warmer than permitted according to the safety standard IEC 61010-1. The 81628B Optical Head can handle optical power up to 40 dBm, however, operation above 38 dBm is at the operator's own risk. Agilent Technologies Deutschland GmbH will not be liable for any damage caused by an operation above 38 dBm.



- **Single module for return loss (RL) test**
- **High dynamic range of 75 dB**
- **Built-in Fabry-Perot laser source for 1310 nm and 1550 nm**
- **Use any external laser source, including tunable laser for swept RL applications**
- **Three easy calibration steps for enhanced accuracy**



Plug&Play for RL Measurement

Portability and cost effective; a single mainframe, single module and single connection to the device under test are all you need to make a return loss (RL) measurement. Agilent's RL test solution solves the complex operation of calibration and is able to exclude measurement uncertainties due to coupler / filter usage in your design. In addition, a built-in FP laser at 1310 nm and 1550 nm enables basic component tests.

Meeting Manufacturing Needs

The need for IL and RL for optical component tests is fulfilled with the RL module when used with an optical power meter - preferably an optical head due to its flexibility. On-board application software supports step-by-step operation with instructions.

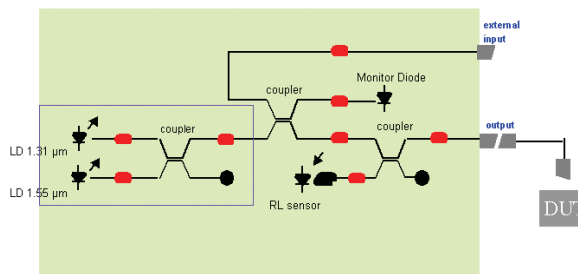

Return Loss Module, Optical Assembly

Swept RL Measurement with Tunable Laser Source

Today's passive component devices are not only characterized at a single wavelength, but over a wide wavelength range using a tunable laser source. The swept wavelength measurement concept is applicable for RL measurements using an Agilent tunable laser source (TLS) in synchronous operation of the two modules.

	81610A		81613A	
Source	external input only		Fabry-Perot Laser (internal)	
Output Power	—		typ. -4 dBm	
Center Wavelength	—		1310 nm / 1550 nm ± 20 nm typ.	
Sensor Element	InGaAs		InGaAs	
Fiber Type	Standard single-mode 9 / 125 μm		Standard single-mode 9 / 125 μm	
External Input	max input power: 10 dBm min input power: 0 dBm damage input power: 16 dBm		— — —	
Wavelength Range for External Input	1250 nm to 1640 nm		—	
Dynamic Range	70 dB		75 dB	
Relative Uncertainty of Return Loss (RL)	with broadband source	with Agilent FP sources	User calibration	Plug&play
RL ≤ 55 dB	< ± 0.25 dB	typ. < ± 0.5 dB	< ± 0.5 dB (typ. < ± 0.3 dB)	typ. < ± 0.6 dB
RL ≤ 60 dB	< ± 0.3 dB	typ. < ± 1.0 dB	< ± 0.6 dB (typ. < ± 0.4 dB)	typ. < ± 1.5 dB
RL ≤ 65 dB	< ± 0.65 dB	typ. < ± 2.0 dB	< ± 0.8 dB (typ. < ± 0.5 dB)	—
RL ≤ 70 dB	< ± 1.7 dB	—	< ± 1.9 dB (typ. < ± 0.8 dB)	—
RL ≤ 75 dB	—	—	typ. < ± 2.0 dB	—
Total Uncertainty add	± 0.2 dB add	typ. ± 0.2 dB	add ± 0.2 dB	add typ. ± 0.2 dB
Dimensions (H x W x D)	75 mm x 32 mm x 335 mm (2.8" x 1.3" x 13.2")		75 mm x 32 mm x 335 mm (2.8" x 1.3" x 13.2")	
Weight	0.6 kg		0.6 kg	
Recommended Recalibration Period	2 years		2 years	
Operating Temperature	10 °C to 40 °C		10 °C to 40 °C	
Humidity	Non-condensing		Non-condensing	
Warm-up Time	20 minutes		20 minutes	



- **Low insertion loss of 0.7 dB**
- **Excellent wavelength flatness**
- **Wide wavelength coverage in both single mode and multi mode fiber**
- **High attenuation resolution of 0.001 dB**
- **Active power control option**



Modular Design, Fit for Various Component and Network Solutions

Agilent's 8157xA variable optical attenuators are a family of plug-in modules for Agilent's lightwave solution platform 8163A/B, 8164A/B and 8166A/B. The attenuator modules 81570A, 81571A and 81578A occupy one slot, while modules 81576A and 81577A occupy two slots. With 17 slots, the Agilent 8166A/B lightwave multichannel system can host up to 17 single slot modules or up to 8 dual slot modules.

Variable Optical Attenuators

The Agilent 81570A, 81571A and 81578A are small, cost effective attenuator modules with high resolution. They feature excellent wavelength flatness and can handle high input power levels. Various calibration features allow the user to set a reference power. Both the attenuation and the power level, relative to the reference power, can then be set and displayed in the user interface. An integrated shutter, which can be used for protection purposes, or to simulate channel drops, is available.

Attenuators for High Optical Input Power

The Agilent modules feature excellent wavelength flatness and can handle high input power levels of 2 mW. Combined with their low insertion loss, they are ideal for optical amplifier tests, such as characterization of EDFAs and of Raman amplifiers, as well as for other multi-wavelength applications, such as DWDM transmission system test.

Attenuators with Power Control

Agilent's 81576A and 81577A attenuators feature power control functionality that allows you to set the output power level of the attenuator. The attenuator module firmware uses the feedback signal from a photo diode after a monitor tap, both integrated in the module, to set the desired power level at the output of the module. When the power control mode is enabled, the module automatically corrects power changes at the input to maintain the output level set by the user. After an initial calibration for the uncertainties at connector interfaces, absolute power levels can be set with high accuracy. The absolute accuracy of these power levels depends on the accuracy of the reference power meter used for calibration.

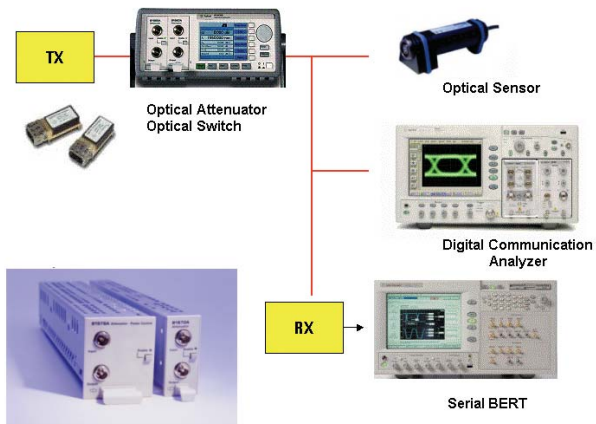

Transceiver and Receiver Test

Wavelength Flatness

The Agilent optical attenuator modules feature excellent wavelength flatness and can handle high input power levels. Combined with their low insertion loss, they are ideal for optical amplifier tests, such as characterization of EDFAs and of Raman amplifiers, as well as for other multi-wavelength applications, such as DWDM transmission system test. One unique feature is a Plug&Play software function which enhances calibration capacity by setting the integral power of a DWDM signal with a known spectrum.

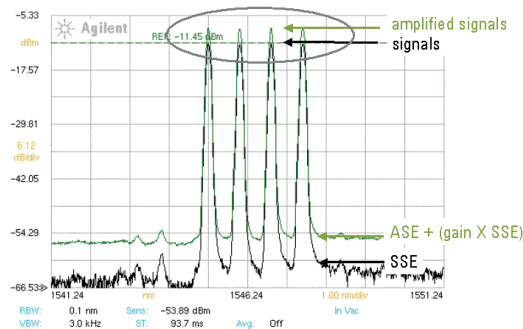

Wavelength flatness preserves multichannel signal flatness for EDFA test.

Modal Fidelity for Multimode Fiber Systems

Signals in multimode fibers are distributed over a range of mode groups that can have different loss and delay in a link. For dependable multimode transceiver testing, the instrument used to set the power level should not change this modal distribution. The bulk-optic filter and collimated beam path of Agilent multimode attenuators are the best way to assure homogeneous attenuation of all input modes.



	8157xA		81578A-050	81578A-062
Connectivity	Straight (81570A) / Angled (81571A) flexible connector interface	Straight (81576A) / Angled (81577A) flexible connector interface		Straight flexible connector interface
Fibre Type	9 / 125 µm SMF28	9 / 125 µm SMF	50/125 µm MMF	62.5/125 µm MMF
Wavelength Range	1200 to 1700 nm	1250 to 1650 nm	700 nm to 1400 nm	
Attenuation Range	0 – 60 dB		0 – 60 dB	
Resolution	0.001 dB		0.001 dB	
		Attenuation Setting	Power Setting	
Repeatability ^[1]	± 0.01 dB	± 0.01 dB	± 0.015 dB ^[2]	± 0.015 dB ^[13, 15]
Accuracy (uncertainty) ^[1,3]	± 0.1 dB ^[4,5]	± 0.1 dB ^[4, 5]	N/A	typ. ± 0.15 dB (800 nm to 1350 nm) ± 0.2 dB (at 850 nm ± 15 nm, 1310 nm ± 15 nm) ^[13, 14]
Settling Time (typical) ^[23]	typ. 100 ms	100 ms	300 ms	typ. 100 ms
Transition Speed (typical)	0.1 to 12 dB/s		typ. 0.1 to 12 dB/s	
Relative Power Meter Uncertainty ^[16,17]	N/A	±0.03 dB ±200 pW ^[16]		
Attenuation Flatness ^[1,5,7,9]	< ± 0.07 dB (typically ± 0.05 dB) for 1520 nm to 1620 nm typically ± 0.10 dB for 1420 nm to 1640 nm			N/A N/A
Spectral Ripple (typical) ^[8]	± 0.003 dB			N/A
Insertion Loss ^[3,5]	Typically 0.7 dB excluding connectors < 1.6 dB (typically 1.0 dB) including connectors ^[10, 13]	Typically 0.9 dB (excluding connectors) <1.8 dB (typically 1.2 dB) Connectors Including ^[10,12]		typ. 1.0 dB (NA = 0.1) typ. 1.3 dB (NA = 0.2) 2.0 dB (NA = 0.2) ^[13, 15] 2.0 dB (NA = 0.2) ^[13, 15] typ. 3.0 dB (NA = 0.27)
Insertion-Loss Flatness (typical) ^[1,12,5]	± 0.1 dB for 1420 nm - 1615nm			N/A
Polarization-Dependent Loss ^[3,10,12]	< 0.08 dBpp (typically 0.03dBpp)	< 0.10 dBpp (typically 0.05 dBpp)		N/A
Return Loss (typical)	45 dB (81570A) / 57 dB (81571A) ^[10,12]	45 dB (81576A) / 57 dB (81577A) ^[10,12]		typ. 27 dB ^[13, 15]
Maximum Input Power ^[14]	+33 dBm		+27 dBm	
Shutter Isolation (typical)	100 dB		typ. 100 dB	
Dimensions (H x W x D)	75 mm x 32mm x 335mm (2.8"x1.3"x13.2")	75 mm x 64mm x 335mm (2.8"x2.6"x13.2")		75 mm x 32 mm x 335 mm (2.8" x 1.3" x 13.2")
Weight	0.9 kg		1.3 kg	0.9 kg
Recommended Recalibration Period	2 years			
Operating Temperature	10 °C to 45 °C			
Humidity	Non-condensing			
Warm-up Time	30 minutes			

- [1] At constant temperature.
- [2] Output power > -40 dBm, input power < +27 dBm. For input power > +27 dBm add typically ± 0.01 dB.
- [3] Temperature within 23°C ± 5°C.
- [4] Input power < +30 dBm; 1550 nm ± 15 nm; typical for 1250 nm < λ < 1650 nm.
- [5] For unpolarized light
- [6] Stepsize < 1 dB; for full range: typically 6 s.
- [7] Relative to reference at 0 dB attenuation.
- [8] Linewidth of source ≥ 100 MHz.
- [9] For λdisp set to 1550 nm and attenuation ≤ 20 dB; for higher attenuation add 0.01 dB per additional dB for 1520 to 1620 nm and 0.02 dB/dB for 1450 to 1640 nm.
- [10] For 1550 nm ± 15 nm.
- [11] Add typically 0.1 dB for 1310 nm ± 15 nm.
- [12] Measured with Agilent reference connectors.
- [13] Effective spectral source bandwidth > 5nm
- [14] For input mode conditions NA = 0.2; for additional ΔNA = 0.01, add ± 0.01 dB typ.
- [15] At 850 ± 15 nm or 1310 ± 15 nm

Ordering information

For the most up-to-date information on Agilent optical attenuators, please contact your Agilent Technologies sales representative or visit our web site at: www.agilent.com/comms/lightwave

Connector Interface

All modules require two connector interfaces, 81000xl series (physical contact).



NEW

N775xA and N776xA Optical Attenuators

- 0.05 dB relative power setting accuracy
- Settling time: 20 ms attenuation, 100 ms power, 200 ms multimode
- Miniature bulk optics for best multimode transfer distribution
- 0.1 to 1000 dB/s or for multimode to 100 dB/s attenuation transition speed (selectable)
- +23 dBm max. input power
- ≤ 1.2 dB insertion loss
- 45 dB single-mode attenuation range (typ.)
- 35 dB multimode attenuation range
- -50 dBm to +20 dBm power setting range
- Fully compatible with setups and programs developed using the Agilent 8157x modular attenuators
- Two instrument configurations can be stored and recalled

The Agilent N775xA and N776xA series compact multi-channel attenuators and power meters are a new class of remote controlled fiber optic instruments for optical transceiver and network integration test. All attenuators include an internal power monitor for each channel to reduce the complexity of closed-loop setups like those needed for very accurate BER testing or eye mask analysis by allowing power to be set directly rather than needing to set an attenuation value. All attenuators feature both attenuation mode and power control mode: In attenuation mode, the calibrated value of attenuation in dB can be set. The rate of attenuation change during setting can be adjusted between 0.1 and 100 dB/s for multimode or up to a very fast 1000 dB/s for single mode. In power control mode, the instrument uses its integrated power monitor to set the desired power level at the output of the module. It automatically corrects for input power changes so that the output power level is maintained. Absolute power levels can be set with high accuracy after an initial offset calibration.

Modal Fidelity for Multimode Fiber Systems

Signals in multimode fibers are distributed over a range of mode groups that can have different loss and delay in a link. For dependable multimode transceiver testing, the instrument used to set the power level should not change this modal distribution. The bulk-optic filter and collimated beam path of Agilent multimode attenuators are the best way to assure homogeneous attenuation of all input modes.

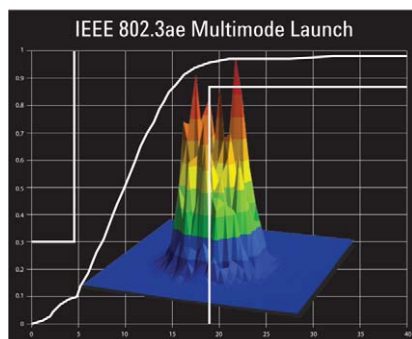

N776xA multi-channel optical attenuators with internal power control



1-channel variable attenuator N7761A



2-channel N7762A SMF attenuator or N7766A MMF attenuator



4-channel N7764A SMF attenuator or N7768A MMF attenuator

N775xA multi-channel optical attenuators with internal power control and external power meter channels

The 2 integrated power meters in the N7751A and N7752A allow convenient measurement of optical power from different stages of the test setup and provide a very convenient and automatic way to calibrate the attenuator power reading to the power actually present at another point, such as the input to the receiver under sensitivity test. This calibration can thus correct for insertion loss due to switches and other components between the attenuator and the point of interest.



1-channel attenuator with two power meter channels N7751A



2-channel attenuator with two power meter channels N7752A

Agilent N775xA, N776xA Multi-Channel Optical Attenuators



NEW

www.agilent.com/find/voa

	N7751A, N7752A, N7761A, N7762A, N7764A		N7766A and N7768A	
Connectivity	FC/APC angled (Option -022) or FC/PC straight (Option -021) contact connector interface		FC/PC straight contact connector interface	
Fiber type	9/125 μm SMF 28		50/125 μm (Option 050) or 62.5/125 μm (Option 062) MMF	
Wavelength range	1260 nm to 1640 nm		800 nm to 1370 nm	
Attenuation range	0 dB to 40 dB (45 dB typ.)		0 dB to 35 dB	
	Attenuation setting mode	Power setting mode	Attenuation setting mode	Power setting mode
Range	0 dB to 40 dB	-50 dBm to +20 dBm	0 dB to 35 dB	-35 dBm to +20 dBm
Resolution	0.01 dB	0.01 dB	0.03 dB	0.03 dB
Repeatability*	typ. ± 0.05 dB for attenuation 0 dB to 30 dB typ. ± 0.10 dB for attenuation 30 dB to 40 dB	± 0.025 dB	± 0.05 dB	± 0.05 dB
Accuracy (uncertainty)*	typ. ± 0.10 dB for attenuation 0 dB to 10 dB typ. ± 0.15 dB for attenuation 10 dB to 20 dB typ. ± 0.40 dB for attenuation 20 dB to 40 dB		typ. ± 0.40 dB	
Relative accuracy (uncertainty)*		± 0.05 dB ± 300 pW		± 0.1 dB ± 300 pW
Polarization dependent loss*	typ. ≤ 0.15 dBpp for attenuation 0 dB to 10 dB typ. ≤ 0.25 dBpp for attenuation 10 dB to 20 dB typ. ≤ 0.5 dBpp for attenuation 20 dB to 40 dB	≤ 0.15 dBpp		
Settling time*	typ. 20 ms*	typ. 100 ms*	typ. 200 ms	typ. 200 ms
Insertion loss*	typ. ≤ 1.2 dB (excluding connectors) ≤ 2.2 dB (including connectors)*		typ. ≤ 1.0 dB (excluding connectors) ≤ 2.0 dB (including connectors)*	
Attenuation transition speed	selectable from 0.1 to 1000 dB/s		selectable from 0.1 to 80 or at > 500	
Relative uncertainty of monitor power meter*	± 0.05 dB ± 300 pW		± 0.1 dB ± 300 pW	
Averaging time of monitor power meter*	2 ms to 1 s		2 ms to 1 s	
Return loss*	typ. 45 dB		typ. 25 dB	
Maximum safe input power*	+23 dBm		+23 dBm	
Optical path blocking	typ. 45 dB		typ. 60 dB	

	N7751A and N7752A
Sensor element	InGaAs
Wavelength range	1260 nm to 1640 nm
Specification wavelength range	(1310 ± 15) nm, (1490 ± 10) nm, (1550 ± 15) nm
Power range	-80 dBm to +10 dBm
Maximum safe power	+16 dBm
Averaging time	2 ms to 1s
Applicable fiber type	Standard SM and MM ≤ 62.5 μm core size, NA ≤ 0.24
Uncertainty at reference conditions*	± 2.5%
Total uncertainty*	± 4.5%
Linearity* at (23 ± 5)°C	± 0.02 dB
Linearity* over operating temperature	± 0.04 dB
Polarization dependent responsivity (PDR)	typ. < ± 0.01 dB (1260 nm to 1580 nm)
Spectral ripple (due to interference)*	typ. < ± 0.01 dB
Drift (dark)*	± 9 pW
Noise pp (dark)3, (1s averaging time, 300s observation time)	< 7 pW*
Return loss*	typ. > 57 dB



- Excellent repeatability, specified over 10,000 random cycles
- Low insertion loss and polarization dependence
- Single-mode or multimode.

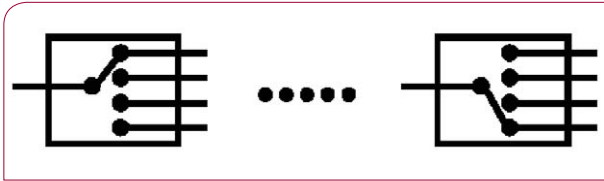

The 1 x 4 optical switch has four positions



Switching Reduces Uncertainty from Connections and Eases Test Automation

These modular switches can be used to avoid repeated reconnections during your measurements and are critical to automated procedures.

The low IL and PDL and high repeatability assure minimum impact of the switch on measurement accuracy.

Switching can be performed from the button on the module, from the mainframe interface and via GPIB control.

The compact form and high performance allow combining switches for multistage setups, like five 1x4 modules.

Modal Fidelity for Multimode Fiber Systems

Signals in multimode fibers are distributed over a range of mode groups that can have different loss and delay in a link. For dependable multimode transceiver testing, the instrument used to set the power level should not change this modal distribution. The Agilent multimode switches are designed with very short collimated paths between fiber, so signals propagate in practically the same distribution as through uninterrupted multimode fiber.

Modular Optical Switch Specifications

81595B		
Switch Type	1 x 4	
Fiber Interface	# 009 single mode	# 062 multimode
Fiber Type	9/125 μ m SMF	62.5/125 μ m MMF
Connectivity	FC/APC – R key	FC/PC straight
Wavelength Range	1270 to 1670 nm	700 to 1400 nm
Insertion Loss (typ.)	< 1.25 dB	< 1.0 dB
Polarization Dependent Loss	typ. 0.07 dBpp	N/A
Repeatability*	\pm 0.03 dB	\pm 0.03 dB
Return Loss	typ. 55 dB	typ. 20 dB
Crosstalk	typ. –70 dB	typ. –70 dB
Switching Time	< 10 ms	
Lifetime	> 10 million cycles	
Maximum Input Power	+20 dBm	
Dimensions (H x W x D)	75 mm x 32 mm x 335 mm (2.9" x 1.3" x 13.2")	
Weight	0.5 kg	
Operating Temperature	10 °C to 45 °C	
Storage Temperature	–40 °C to 70 °C	
Humidity	Non-condensing	
Warm-up Time	30 min.	



- **Precise manual and remote adjustments of polarization state**
- **Nine Save/Recall registers of SOP**
- **Continuous auto scanning, tuning the SOP across the entire Poincare sphere**



Developing and manufacturing competitive, high-value components and systems for today's optical industries requires precise attention to polarization sensitivity. The Agilent 8169A polarization controllers can help by saving time, money and effort when measuring and working with polarization sensitive devices.

Polarization sensitive devices include EDFAs, single-mode fiber, polarization maintaining fiber, isolators, switches, lasers, couplers, modulators, interferometers, retardation plates and polarizers. Device performance will be affected by polarization-dependent efficiency, loss, gain and polarization mode dispersion. These polarization phenomena enhance or degrade performance depending on the application area, be it communications, sensors, optical computing or material analysis.

An Important Part of a Measurement System

A polarization controller is an important building block of an optical test system because it enables the creation of all possible states of polarization. The polarized signal stimulates the test device while the measurement system receiver monitors the test device's responses to changing polarization. Sometimes polarization must be adjusted without changing the optical power. At other times, polarization must be precisely synthesized to one state of polarization (SOP) and then adjusted to another SOP according to a predetermined path.

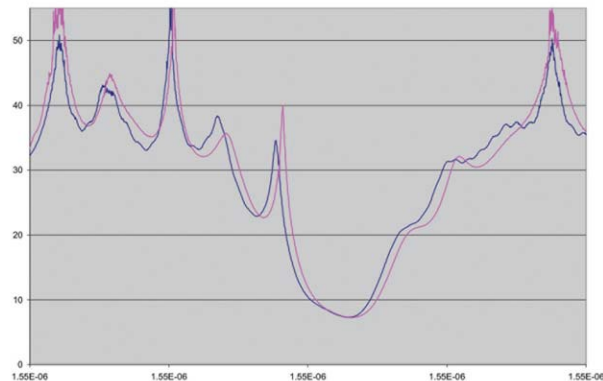

Characterizing polarization effect of passive optical component

The Agilent 8169A Polarization Controller

The Agilent 8169A provides polarization synthesis relative to a built-in linear polarizer. The quarter-wave plate and half-wave plate are individually adjusted to create all possible states of polarization. Deterministic algorithms within the Agilent 8169A enable the transition path from one state of polarization on the Poincare sphere to another to be specified along orthogonal great circles. These features are important because device response data can be correlated to specific states of polarization input to the test device. PDL measurement of DWDM components using the Mueller method is one of the main applications. The Mueller method stimulates the test path with four precisely known states. Precise measurement of the corresponding output intensities allows calculation of the upper row of the Mueller matrix, from which PDL is in turn calculated. This method is fast, and ideal for swept wavelength testing of PDL.

Specifications

Specifications describe the instruments' warranted performance over the 0° C to +55° C temperature range after a one-hour warm-up period. Characteristics provide information about non-warranted instrument performance. Specifications are given in normal type. Characteristics are stated in *italicized* type. Spliced fiber pigtail interfaces are assumed for all cases except where stated otherwise.

Description	Agilent 8169A
Operating Wavelength Range	1400 to 1640 nm
Insertion Loss ^{2,3}	< 1.5 dB
Variation over 1 full rotation	< ± 0.03 dB
Variation over complete wavelength range	< ± 0.1 dB
Polarization Extinction Ratio ⁴	> 45 dB (1530 to 1560 nm) > 40 dB (1470 to 1570 nm) > 30 dB (typ.) (1400 to 1640 nm)
Polarization Adjustment	
Resolution ⁴	0.18° (360°/2048 encoder positions)
Fast axis alignment accuracy at home position ^{5,6}	± 0.2°
Angular adjustment accuracy: minimum step size	± 0.09°
greater than minimum step size ⁵	< ± 0.5°
Settling time (characteristic)	< 200 ms
Memory Save/Recall registers	9
Angular repeatability after Save/Recall ^{5,6}	± 0.09°
Number of scan rate settings	2
Maximum rotation rate ⁶	360°/sec
Maximum Operating Input Power Limitation	+23 dBm
Operating Port Return Loss (characteristic)	
Total reflection – Individual reflections	> 60 dB
Power Requirements	48 to 60 Hz 100/120/220/240 Vrms 45 VA max
Weight	9 kg (20 lb)
Dimensions (H x W x D)	100 mm x 426 mm x 445 mm 3.9 in x 16.8 in x 17.5 in



Instrument Setup Polarization analyzer setup

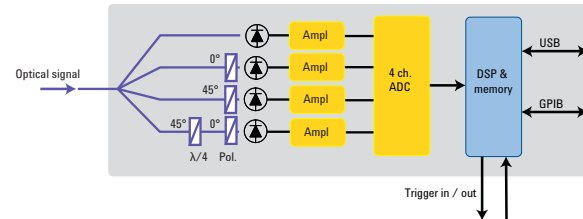

The instrument setup of the Agilent N7781B/BD polarization analyzer is shown in the figure above. It consists of a unique polarimeter optics and a high-speed sampling subsystem. The measurement principle is based on splitting the light into four sub beams which are filtered through different polarizers. The resulting four power levels are evaluated using on-board calibration data to obtain an accurate SOP- and DOP-measurement.

General Information

The Agilent N7781B is a compact high-speed polarization analyzer which provides comprehensive capabilities for analyzing polarization properties of optical signals. This includes representation of the State of Polarization (SOP) on the Poincaré Sphere (Stokes Parameter). The on-board algorithms together with the on-board calibration data ensure highly accurate operation across a broad wavelength range.

Due to its real time measurement capability (1 MSamples/s) the instrument is well suited for analyzing disturbed and fluctuating signals as well as for control applications requiring real time feedback of polarization information.

Analogue data output ports are provided, for example for support of control loops in automated manufacturing test systems.

Powerful User Interface and remote programming capabilities are provided by the Polarization Navigator software package of the N7700A Photonic Application Suite.

Recirculating Loop Experiments

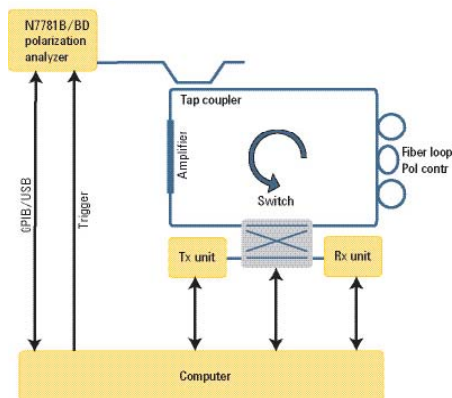

Managing the polarization properties of the fiber loop is mandatory for successfully conducting experiments with such structures. The Agilent N7781B/BD high speed polarization analyzer allows an analysis of the SOP and the DOP of the circulating signal. The high sampling rate and the trigger capabilities of the instrument, allow detailed analysis of the evolution of the SOP and the DOP along each revolution.

Key Features:

- **Measurement of Stokes Parameter (SOP)**
- **Measurement of degree of polarization (DOP)**
- **High-speed operation (>1 MSamples/s)**
- **Analog output port for DOP/SOP data**
- **Robust, no moving parts**

Applications

- Monitoring / Measurement of
- State of Polarization (SOP)
 - Stokes Parameter
 - Degree of Polarization (DOP)
 - High-Speed Analysis of SOP/DOP of Recirculating Signal

Event Trigger Example

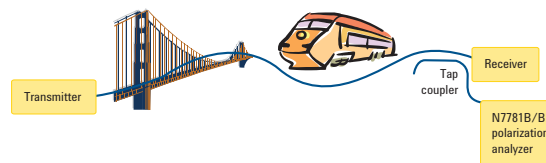

Advanced communication systems are sensitive to rapid polarization changes ("events") on fiber links. Such events may be caused for example by trains passing by or by vibrations on bridges. The speed of the polarization events are of concern for system integrators and network operators. The event trigger function of Agilent's N7781B allows detecting and recording such events.



Agilent N7781B Polarization Analyzer

Wavelength

Specification Wavelength Range	1270 nm to 1375 nm (Opt 300, O-Band) 1270 nm to 1375 nm, 1460 nm - 1620 nm (Opt 400, O/C/L-Band) 1460 nm to 1620 nm (Opt 500, C/L-Band)
Operating Wavelength Range ^[2]	1260 nm to 1640 nm

Polarization Analysis

SOP Uncertainty ^{[3],[4]} (typical)	1.5°
DOP Uncertainty ^[3]	± 2.0%
DOP Uncertainty after User Calibration ^{[3],[5]} (typical)	± 0.5%
Maximum Sampling Rate	up to 1 MHz

Optical Power Measurement

Relative Power Uncertainty ^[3]	C/L-Band: ± 0.03 dB (± 0.02 dB typ.) O-Band: ± 0.07 dB (± 0.04 dB typ.)
Input Power Range	-50 dBm to +7 dBm
Maximum Safe Optical Input Power	+12 dBm

[1] Ambient temperature change max. ± 0.5°C since normalization. Specification valid on day of calibration.

[2] SOP/DOP measurements are possible outside the specification wavelength range if a manual user calibration is performed.

[3] Input power > -30 dBm

[4] DOP > 95%

[5] User calibration requires a source with DOP = 100%. User calibration is valid for a fixed wavelength.



General Information

Agilent's N7782B series of PER analyzers has been designed for high speed and highly accurate testing of the polarization extinction ratio (PER) in PM fibers. The polarimetric measurement principle guarantees reliable measurements of PER values of up to 50dB.

The real time measurement capability in combination with automation interfaces makes this unit ideally suited for integration in manufacturing systems, for example pig-tailing stations for laser diodes and planar waveguide components. Analog interfaces are provided for integration of the system in control loop applications.

Key Benefits

- **Accurate PER-measurement up to 50dB**
- **Real-time display of PER**
- **Easy-to-use: Reliable results independent of operator skill set**
- **Swept-wavelength and heating / stretching method available**
- **Measurement of the PER versus wavelength**
- **Fast / slow axis detection**
- **Instruments available for 1260nm up to 1640nm**
- **Internal fixed wavelength sources at 850nm / 1310nm / 1550nm available.**

Applications

- **Laser Diode PMF Pig-tailing** Alignment of the PM fiber during the pig tailing process is supported by real-time display of the PER and the optical power.
- **PMF Splicing** In order to support the alignment during the splicing process of PM fibers the Agilent N7782B provides real time display of the optical power and of the angular misalignment of the two fibers
- **PM component characterization** measurement of the PER on PM components like fiber polarizers, PMF couplers, PMF splitters, etc.
- **Characterization of PMF cross-coupling** polarization crosstalk in a PM fiber is measured and displayed as PER
- **PM splice characterization** The angular misalignment of a PM splice can be measured in a non-destructive way. Even multiple splices in a chain can be characterized independently.

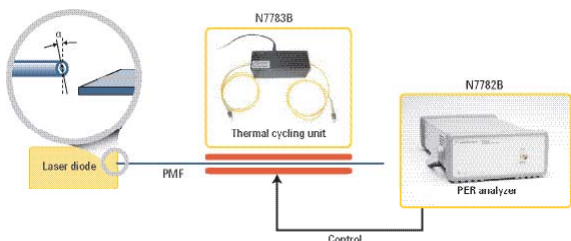

Agilent N7782B and N7783B Application Examples

The Wavelength Scanning Method

Using Agilent's tunable laser source 81600B series in combination with the Agilent N7782B PER analyzer allows measuring the PER as a function of wavelength.

The Heating / Stretching Method

The Heating / Stretching method provides accurate measurements of the PER at a single wavelength.

This method supports in particular well the measurement using narrow-band laser sources.

An optional internal laser source allows stand-alone operation of the system.

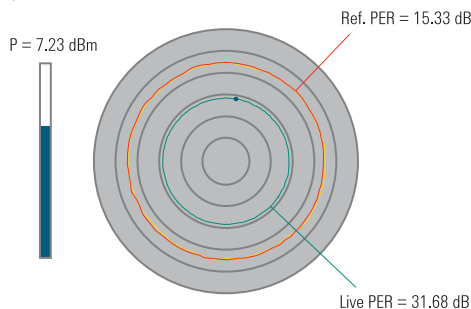

Agilent's thermal cycling unit N7783B is fully controlled by the Agilent N7782B PER analyzer and allows accurate and repeatable cycling of the temperature of the fiber under test. The PER measurement system consisting of the Agilent N7782B and the Agilent N7783B shows excellent accuracy and repeatability. Ease of use and automation interfaces, such as analog output ports for active alignment, make it particularly useful for production environments.

Splice Angle Characterization



For characterizing an optical connection between two polarization maintaining fibers (PMFs), such as an optical splice, two thermal cycling units (Agilent N7783B) can be used. This eliminates the influence of input polarization or subsequent fibers at the output and isolates the angular misalignment of the connection located between the two thermal cycling units.



Specifications^[1] N7782B PER Analyzer

Wavelength

Specification Wavelength Range	1270 nm to 1375 nm (Opt 300, O-Band) 1270 nm to 1375 nm, 1460 nm - 1620 nm (Opt 400, O/C/L-Band) 1460 nm to 1620 nm (Opt 500, C/L-Band)
Operating Wavelength Range ^[2]	1260 nm to 1640 nm (Opt 300 / 400 / 500)

PER Analysis

PER Range ^[3,4]	0 - 50 dB (Opt 300 / 400 / 500)
----------------------------	---------------------------------

Optical Power

Input Power Range	-50 dBm - +7 dBm (Opt 300 / 400 / 500)
-------------------	--

Internal Laser Source

Wavelength	Opt. 401 (O-Band): 1290 nm to 1360 nm, 1310 nm typ. Opt. 501, 401 (C-Band): 1510 nm to 1580 nm, 1550 nm typ.
Output Power ^[5] (typical)	Opt. 401 (O-Band): -12 dBm Opt. 501, 401 (C-Band): -10 dBm

- [1] Ambient temperature change max. $\pm 0.5^{\circ}\text{C}$ since normalization. Specification valid on day of calibration.
- [2] PER measurements are possible outside the specification wavelength range if the user performs a manual calibration. Note that a fully polarized light source is needed for calibration.
- [3] Input power > -30 dBm
- [4] Narrow-band light source with DOP > 95% needed.
- [5] At room temperature.

Agilent N7783B Thermal Cycling Unit Characteristics

Fiber jacket diameter	up to 3 mm
Ambient Temperature Range	20 °C - 30 °C
Minimum Peak-to-Peak Temperature Tuning Range	50K
Power	100 - 240 VAC, < 36W
Dimensions (H x W x D)	64 mm x 160 mm x 61 mm



Agilent offers a wide range of instruments that control the state of polarization (SOP) of an optical signal for various applications. Some measurements should confirm that the performance of an optical component does not exceed acceptable dependence on polarization, such as tests for polarization dependent loss (PDL) and polarization mode dispersion (PMD). In other cases, a signal with specific polarization should be tested.

Agilent N7784B, N7785B, and N7786B



N7784B



N7785B



N7786B

These 3 instruments are all based on high-speed solid state optics to rapidly switch the polarization of an incoming signal. They are used with polarized input signals from lasers and can adjust, scan or align the output state of polarization. The instruments are controlled from an external PC and convenient graphical user interface control is provided with the included Polarization Navigator software, distributed with the N7700A Photonic Application Suite. Automated control is provided by the GPIB and USB interfaces.

N7785B Synchronous Scrambler

The N7785B Synchronous Scrambler provides fast SOP switching in response to internal or external triggering. This supports optical network simulations that often require switching of the signal SOP in a random way within a few microseconds, such as in recirculating loop tests. The SOP is switched rapidly, and then held for a predefined time until it again switches to a new SOP. The output SOP is controlled but not determined

by the N7785B and will be changed if the input SOP changes. The output SOP can be adjusted to a desired external condition, such as maximizing the signal through a polarizer.

Application routines in the Polarization Navigator software can be used for random scrambling and continuous scrambling (where the state of polarization moves smoothly about the Poincaré sphere, similar to a flipper-style scrambler) over a wide range of speeds.

N7784B Polarization Controller

The N7784B Polarization Controller provides alignment and fast stabilization of SOP into polarization maintaining fiber (PMF) or with respect to an external condition by adding an analog feedback and polarizer path to the basic N7785B configuration.

For alignment into PMF, the input signal is first routed through the fast switching controller with single-mode fiber (SMF) and is available at an intermediate front panel output. An external jumper fiber is used to route the signal into the polarizer path consisting of a polarizing beam splitter with one output monitored by a photodetector. The other output is coupled to the front panel output with PMF. The signal from the photodetector is used to actively align and stabilize the input signal into the PMF output that could then be connected to a modulator or other polarization dependent device.

Similarly, the signal can be used directly from the intermediate output and a user-configured setup can provide the feedback for optimizing the desired SOP from the instrument.

N7786B Polarization Synthesizer

The N7786B Polarization Synthesizer includes internal SOP monitoring and feedback via a tap coupler to determinately set and hold any chosen states or sequences of polarization. This allows generation of sequences with chosen relative SOP orientation. This is often used for component analysis based on Mueller Matrix or Jones Matrix analysis. The uniquely fast switching supports the new single-sweep spectral PDL measurements with the N7700A software, which eliminates sensitivity to environmental stability and minimizes measurement time. Analysis of these results into transmission spectra of the primary device axes (like TE and TM) is also achieved in this way. The real-time monitoring and logging of output SOP permits accurate calculation including the wavelength dependence of the SOP.

The real-time monitoring and feedback also are used in this instrument to provide stabilized SOP, even with fluctuation and drift of the input SOP.

The output SOP can be defined in following ways:

- **Set-and-forget:** When the front panel button is pushed, the current SOP is stored and maintained, even if polarization changes occur at the instrument input
- **Defined Stokes:** The target output SOP can be defined by the user using the Stokes parameters

The Polarization Navigator also has a convenient button to quickly change from a manually adjusted SOP to the corresponding orthogonal state, as can be used to check extinction ratio.



Specifications^[1] N7784B Polarization Controller

Wavelength	
Operating Wavelength Range	1260 to 1640 nm
Wavelength Range in Stabilizer Mode ^[2]	1520 to 1580 nm
Polarization Control and Stabilization	
SOP Switching Time (open-loop)	< 10 μ s
PER at PMF Output (typical)	> 23 dB
Stabilizer Response Time ^[3] (typical)	2 ms
Optical Power	
Insertion Loss Port I > Port II ^[4]	< 3.5 dB (< 3.0 dB, typ.)
Insertion Loss Port III > Port IV ^[5]	< 1.8 dB (< 1.4 dB, typ.)
PDL Port I > Port II (typical)	< 0.2 dB (C/L - Band)
Maximum Safe Input Power	Port I: 20 dBm Port III: 3 dBm
Input Power Range in Stabilizer Mode	Port III: -30 dBm to 0 dBm

[1] Ambient temperature change max. $\pm 0.5^{\circ}\text{C}$ since normalization. Specification valid on day of calibration;

[2] Outside the stabilizer wavelength range, the PER at PMF Output may be degraded;

[3] Input power at Port III > -30 dBm, response to an immediate step of 180° on the Poincaré sphere;

[4] For SOP scrambling/switching, only ports I/II are used;

[5] Valid for optimum input polarization at PBS input (Port III). Add insertion loss of port I/II and III/IV to obtain total insertion loss for SOP stabilizing mode.

Specifications^[1] N7785B Synchronous Scrambler

Wavelength	
Operating Wavelength Range	1260 to 1640 nm
Polarization Control	
SOP Switching Time	< 10 μ s
Optical Power	
Insertion Loss	< 3.5 dB (< 3.0 dB, typ.)
PDL (typical)	< 0.2 dB (C/L - Band)
Maximum Safe Input Power	20 dBm

[1] Ambient temperature change max. $\pm 0.5^{\circ}\text{C}$ since normalization. Specification valid on day of calibration.

Specifications^[1] N7786B Polarization Synthesizer

Wavelength	
Specification Wavelength Range	1270 to 1375 nm, 1460 to 1620 nm (Opt 400, O/C/L-Band) 1460 to 1620 nm (Opt 500, C/L-Band)
Operating Wavelength Range ^[2]	1260 to 1640 nm
Polarization Control and Stabilization	
SOP Switching Time (non deterministic)	< 10 μ s
SOP Cycling Time ^[3]	< 25 μ s
Remaining SOP Error after deterministic SOP setting (typical) ^[4]	< 3° at input SOP movement rate of 1.2 rad/s < 6.5° at input SOP movement rate of 40 rad/s
Polarization Analysis^[7]	
SOP Uncertainty ^{[3],[4]}	1.5°
DOP Uncertainty ^[3]	$\pm 2.0\%$
DOP Uncertainty after User ^{[3],[5]} Calibration (typical)	$\pm 0.5\%$
Optical Power Measurement^[7]	
Relative Power Uncertainty ^[3]	C/L-Band: ± 0.14 dB (± 0.12 dB typ.) O-Band: ± 0.16 dB (± 0.14 dB typ.)
Input Power Range	-38 dBm to +19 dBm
Optical Power	
Insertion Loss	< 4.0 dB (< 3.5 dB, typ.)
PDL (typical)	< 0.2 dB (C/L - Band)
Maximum Safe Input Power	20 dBm

[1] Ambient temperature change max. $\pm 0.5^{\circ}\text{C}$ since normalization. Specification valid on day of calibration; [2] SOP/DOP measurements are possible outside the specification wavelength range if the user performs a manual calibration; [3] Input power > -20 dBm; [4] DOP > 95%; [5] User calibration requires a source with a known DOP; [6] The instrument adaptively finds the polarization controller settings to let the SOP cycle through user-defined polarization states (closed loop operation). After having found these settings, the SOP can cycle through the polarization states in open loop operation; [7] This value is defined to be 5 times the standard deviation of the angular SOP error on the Poincaré sphere. Valid if controller is turned on. Power at instrument input > -10 dBm; [7] The polarization analyzer readout reflects the SOP at the instrument output. Thus, effects caused by the internal polarization controller are included.



N7788BD Bench-top Mainframe with built-in PC



N7788B Bench-top Mainframe

General Information

Agilent Technologies pushes the limits of component measurements with the N7788B and N7788BD Component Analyzer. Its proprietary technology is comparable with the well-known Jones-Matrix-Eigenanalysis (JME) which is the standard method for measuring Polarization Mode Dispersion (PMD) or differential group delay (DGD) of optical devices.

Compared to the JME, Agilent's new single scan technology offers a range of advantages:

A complete set of parameters:

- DGD/ PMD / PDL / 2nd order PMD
- Power / Loss
- TE / TM-Loss
- Principal States of Polarization (PSPs)
- Jones and Mueller Matrices

For measuring these parameters, the N7788B/BD is used together with an Agilent continuous-sweep tunable laser like the 81600B, and control is provided with the Polarization Navigator package of the N7700A Photonic Application Suite.

The N7788B/BD also provide the full polarization analysis functionality of the N7781B.

Key Benefits

Highest Accuracy in a single sweep: no averaging over multiple sweeps required

High Measurement Speed:

Complete measurement across C/L-band in less than 10 seconds (no need to wait for many averages)

Robustness against fiber movement / vibration and drift:

Fixing fibers with sticky tape on the table or even operation on isolated optical table is not required!

No limitation on optical path length of component

The internal referencing scheme guarantees reliable and accurate measurements.

Applications

- Fiber characterization: SMF, PMF, DCF
- Passive component testing: filters, isolators, circulators
- Dynamic component / module testing: OADM / ROADM
- Active component testing: EDFAs, SOAs, VOAs
- Link test: In-Channel measurements across amplifiers

Designed for the Manufacturing Floor

High Throughput:

A complete analysis across the C and the L band is performed in less than 10 seconds!

Software Drivers:

A range of software drivers is available for external control of the system. This allows easy integration in common ERP systems.

Remote Control:

Control of the instrument through LAN or via the Internet is supported. This supports automation as well as trouble shooting.

Report Generation:

Generating PDF reports is supported. The content including layout is configurable by the user.

Real-time Power Readout:

High throughput measurement of non-connectored components is supported by providing a real time power readout which enables fiber coupling of the new device

Barcode Scanner:

Using Barcode scanner is supported for quick transfer of the DUT serial number

Instrument Setup and Application Examples

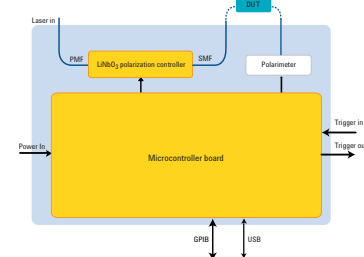

The instrument setup is shown in the figure above. A Lithium-Niobate polarization controller determines the input polarization to the DUT. While the tunable laser source¹ is sweeping over the desired wavelength range, a polarimeter analyzes the output state of polarization while input polarization is being modified. The result will be a highly accurate device characterization with respect to DGD/PDL/Loss etc. Furthermore, the internal optical switch provides continuous self calibration for excellent repeatability.

Resolving TE/TM Insertion Loss

The TE/TM-function allows accurate determination of the minimum and maximum loss of the DUT at each wavelength.

Due to birefringence, optical filters tend to show different transmission functions depending on the polarization state.

⁽¹⁾ not included



Long Term Measurements

The capability of performing quick PMD-measurements makes this measurement system well-suited for collecting long-term PMD data. The PC software allows to continuously collect the spectral PMD data and store it on the hard disc. The data can then be visualized as pseudo-color plot (see figure).

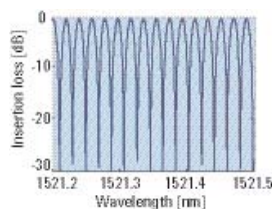
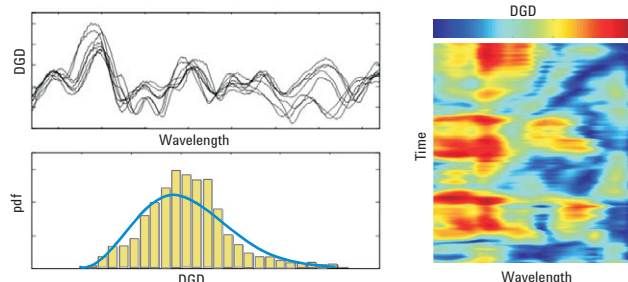

Excellent Spectral Resolution

Due to the excellent spectral resolution with the 81600B TLS, the Agilent N7788B/BD is best suited for intra-channel DGD/PDL characterization. The All-Parameter-JME algorithm allows flexible adjustments of the wavelength resolution without the need to repeat the measurement. This simplifies finding the optimum trade-off between PDL/DGD accuracy and wavelength resolution.

Specifications^[1] N7788B/BD Optical Component Analyzer

Wavelength

Specification Wavelength Range	1270 to 1375 nm (Opt 300, O-Band) 1270 to 1375 nm, 1460 nm to 1620 nm (Opt 400, O/C/L-Band) 1460 to 1620 nm (Opt 500, C/L-Band)
Operating Wavelength Range ^[2]	1260 nm to 1640 nm

Differential Delay

DGD Uncertainty ^[3]	Resolution 2,0 nm: $\pm (30 \text{ fs} + 0,3\% \times \text{DGD})$ Resolution 0,1 nm: $\pm (30 \text{ fs} + 3,0\% \times \text{DGD})$
DGD Measurement Range ^[3]	0 ... 1000 ps
PMD Uncertainty ^[4]	$\pm (30 \text{ fs} + 2,0\% \times \text{PMD})$
PMD Repeatability (typical)	$\pm 3 \text{ fs}$
PMD Measurement Range ^[4]	0 - 300 ps

Loss

PDL Uncertainty ^[5]	C/L-Band: $\pm (0,05 \text{ dB} + 4\% \times \text{PDL})$ O-Band: $\pm (0,10 \text{ dB} + 4\% \times \text{PDL})$
PDL Repeatability (typical)	$\pm 0,05 \text{ dB}$
Insertion Loss Uncertainty (typical) ^[3]	C/L-Band: $\pm 0,03 \text{ dB}$ O-Band: $\pm 0,07 \text{ dB}$
Insertion Loss Dynamic Range (typical) ^[3]	> 41 dB (for TLS power levels higher than -6 dBm, increase value accordingly)

Polarization Analysis

See N7781B Specifications

Optical Power Measurement

See N7781B Specifications

- [1] Ambient temperature change max. $\pm 0,5^\circ\text{C}$ since normalization. Valid for 81600B tunable laser source family. Tunable laser power set to -6 dBm. Sweep over specification wavelength range. Specification does not include instability in test device. Specified loss ranges include loss of test device and any additional switches or connections in the optical path. Specification valid on day of calibration.
- [2] Only SOP/DOP measurements are possible outside the specification wavelength range if the user performs a manual calibration.
- [3] DUT properties: Insertion Loss < 30 dB, PDL < 1 dB, DGD < 150 ps. Specification is typical for DGD > 150 ps.
- [4] DUT properties: Insertion Loss < 41 dB, PDL < 3 dB, PMD < 50 ps. Applies for highly mode-coupled devices such as single mode fibers. Specification applies for PMD being the averaged DGD over a wavelength span of 100 nm. Specification is typical for PMD > 50 ps.
- [5] DUT properties: Insertion Loss < 25 dB, PDL < 6 dB. Note: DUT connectors are considered being part of the DUT. Thus, angled connectors will add to the device PDL.



- **Fastest measurement speed for manufacturing test**
- **Highest CD and PMD accuracy and resolution for manufacturing and R&D • Specified operation over 1260 to 1640 nm (O-L band)**
- **2nd-order PMD, GD-ripple and other analysis functions**
- **Expandable for enhanced PDL accuracy and multiport use**
- **Industry-standard measurements with the modulation phase shift method for measurements to any length**



The Agilent 86038B continues Agilent's tradition in measuring chromatic dispersion with this instrument for full dispersion and insertion loss analysis in fast swept-wavelength measurements with polarization resolution. It simultaneously measures chromatic dispersion (CD) and group delay, polarization mode dispersion (PMD) and DGD, insertion loss (IL), and polarization dependent loss (PDL) and optical length and phase. An advanced implementation of the industry standard modulation phase shift method (MPS) provides fast CD and GD traces with high selectable wavelength resolution and low noise without repeated averaging. Use of the polarization resolved MPS method with a wide range of modulation frequency allows measurements to any device length and to highest resolution.

The 86038B uses the industry standard Modulation Phase Shift (MPS) method for both GD/CD and DGD measurements. The advanced implementation of the MPS method delivers both high GD and wavelength resolution. The basic method is standardized in IEC 60793-1-42. The method is documented for DGD and PMD in other standards such as IEC 61280-4-4. This is the one method that can determine a DGD value from measurements only at that wavelength, allowing high resolution with low noise.

The 86038B uses fast swept measurements that are ideal for manufacturing. On the manufacturing floor, success depends on high volume throughput, fast ramp-up and reduced cost of test. Trust in your results is vital. The MPS method used on the 86038B avoids sensitivity to thermal drifts and mechanical vibrations. And the Drift Correction feature assists in obtaining repeatable and stable measurements even in an unstable environment.

Key Capabilities

Simultaneous GD, CD, DGD, PMD, IL, and PDL spectra with a single connection and a single setup reduce test time, instrument footprint and measurement uncertainty.

CD uncertainty: ± 0.07 ps/nm; $\pm 0.3\%$ CD

Zero dispersion wavelength uncertainty: ± 0.015 nm

Group delay repeatability: $< \pm 0.03$ ps ($< \pm 30$ fs)

PMD uncertainty: ± 0.07 ps

Differential group delay uncertainty: ± 100 fs

Enhanced PDL and insertion loss accuracy: PDL < 0.05 dB, Loss < 0.02 dB

High speed swept measurements: DGD measurements over 100nm can be obtained in less than 30 seconds.

GD/CD measurements automatically corrected for PMD

Allows very accurate CD measurements

6 polarization-state measurements

This selectable method adds additional accuracy to polarization measurements, especially over wide wavelength ranges

Up to 4-port component testing:

Agilent's 81595B Modular Optical Switch allows testing of up to 4 ports of a multichannel DUT.

Wide dynamic range: > 40 dB

Flexible choice of wavelength range:

from 1260 nm to 1640 nm

Supports multiple wavelength band operation

by controlling up to 4 tunable lasers. Automatic laser switching is available on request.

Drift correction:

Provides excellent stability and accuracy when the environmental conditions of the room or the test device are gradually changing.

Selectable and high wavelength resolution:

Resolution to < 0.2 pm for challenges like GD ripple characterization and up to 2.5 GHz MPS modulation frequency for lowest noise fiber characterization.

Powerful remote control:

Write your own applications for enhanced measurement control and analysis

Fast and accurate length measurement

In a few seconds, the fiber or device length can be determined, short or long. The measurement, according to the standard IEC 60793-1-22 and using the modulation frequency range of the 86038B supports determination of CD and PMD coefficients of fiber, the dependence of dispersion on length. The short length accuracy of 0.02 mm corresponds to absolute delay measurements with 100fs accuracy.



Specifications (condensed: full details in 86038B Data Sheet)

(swept wavelength mode; ambient temperature change $< \pm 0.5^{\circ}\text{C}$ since normalization; TLS power, 0 dBm; sweep over specified wavelength range)

Group Delay and Differential Group Delay Measurement

(modulation frequency, 2 GHz; IF bandwidth, 70Hz; wavelength increment, 1nm; PDA correction)

Accessories

	86038B - 505	81595B 1 x 4 Modular Optical Switch for 4 Port Operation			
	86038B - 510	Verification Fiber			
	86038B - 520	Spare Hard Drive			
For device insertion loss		≤ 4 dB	≤ 10 dB	≤ 20 dB typ.	≤ 30 dB typ.
Relative GD Uncertainty		± 50 fs	± 100 fs	± 350 fs	± 4 ps
Relative GD Repeatability		± 30 fs	± 50 fs	± 300 fs	± 3.5 ps
DGD Uncertainty		± 100 fs \pm 2.5% of DGD	± 150 fs \pm 3% of DGD	± 500 fs \pm 2% of DGD	± 5 ps \pm 12% of DGD
DGD Repeatability		± 50 fs \pm 1% of DGD	± 100 fs \pm 2% of DGD	± 350 fs \pm 1.5% of DGD	± 3.5 ps \pm 12% of DGD
PMD Uncertainty (typ., av. over 100 nm Range)		± 70 fs \pm 2% of PMD	± 100 fs \pm 2% of PMD	± 300 fs \pm 2% of PMD	± 3 ps \pm 4% of PMD
CD Uncertainty (ps/nm) at 1 nm wavelength resolution		$\pm (0.07 +$ 0.3% of CD)	$\pm (0.14 +$ 0.3% of CD)	$\pm (0.5 +$ 0.3% of CD)	$\pm (6 +$ 0.3% of CD)
Zero-dispersion wavelength uncertainty for a fiber with 1 ps/nm ² l-slope (derived from specification)		± 0.015 nm	± 0.022 nm	± 0.058 nm	± 0.6 nm
Modulation Frequency		Settable: 5 MHz to 2.5 GHz			
Length Uncertainty		$\pm (0.02$ mm + 0.00001 of length, (typ., specification valid for ≤ 50 km)			
PDL uncertainty		Without Option 400: $\pm (0.15$ dB + 3% of PDL) typ. With Option 400: $\pm (0.05$ dB + 3% of PDL); loss 0-4 dB.			
Gain/Loss Uncertainty		Without Option 400: $\pm (0.1$ dB + 5% of PDL) typ. With Option 400: ± 0.02 dB, loss ≤ 10 dB; ± 0.04 dB, loss ≤ 30 dB;			
Dynamic Range		> 40 dB, typical			
Wavelength Range		Full Range (nm)	Range of Specifications (nm)		
Option #120 or 320		1440 to 1640	1475 to 1625		
Option #116 or 316		1495 to 1640	1510 to 1620		
Option #115 or 315		1450 to 1590	1480 to 1580		
Option #114 or 314		1370 to 1495	1420 to 1490		
Option #113 or 313		1260 to 1375	1270 to 1350		
Abs. wavelength uncertainty (swept/stepped mode)		With Option 410: ± 4 pm typ. / ± 2 pm typ. Without Option 410: ± 6.1 pm typ. / ± 10 pm, ± 3.6 pm typ.			
Rel. wavelength uncertainty (swept/stepped mode)		± 4 pm typ. / ± 5 pm, ± 2 pm typ.			
Assembled dimensions (HxWxD) (single TLS configuration)		555 mm x 435mm x 555 mm 54 kg (120 lb).			
Performance Options	86038B - 400	Enhanced PDL and Loss Accuracy			
	86038B - 410	Add 86122A multi-wavelength meter for ± 1.0 pm accuracy			



81000HI - E-2000 Connector Interface

For **physical** contact connections

Recommended for angled and straight connector interfaces. Use with sources. Not for sensors.



81000PI - E-2000 Connector Interface

For **non-physical** contact connections

Recommended for angled and straight connector interfaces. Use with sensors.

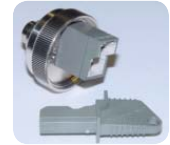

81000LI - LC/F3000 Connector Interface

For **physical** contact connections

Recommended for angled and straight connector interfaces. Use with sources.



81002LI - LC/F3000 Connector Interface

For **non-physical** contact connections

Recommended for angled and straight connector interfaces. Use with sensors.



81000FI - FC/PC Connector Interface

N-keying (key slot = 2.20mm nominal)

For physical and non-physical contact connections

Recommended for angled and straight connector interfaces



81000NI - FC/APC Connector Interface

R-keying (key slot = 2.00mm nominal)

For physical and non-physical contact connections

Recommended for angled and straight connector interfaces



81000MI - MU Connector Interface

For **physical** contact connections

Recommended for angled and straight connector interfaces. Use with sources.

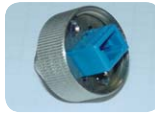

81002MI - MU Connector Interface

For **non-physical** contact connections

Recommended for angled and straight connector interfaces. Use with sensors.

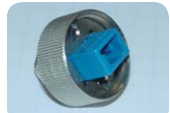

81000KI - SC Connector Interface

For physical and non-physical contact connections

Recommended for angled and straight connector interfaces



81000VI - ST Connector Interface

For physical and non-physical contact connections

Recommended for angled and straight connector interfaces



81000SI - DIN 4108/47256 Connector Interface

For physical and non-physical contact connections

Recommended for angled and straight connector interfaces



81000BR - HMS-10 Reference Reflector

- Return Loss = 0.18 dB \pm 0.1 dB (96% \pm 2%) typ.
- Wavelength range: 1200 nm to 1600 nm

A gold-plated HMS-10 connector for use in measuring return loss of optical connectors. It allows you to establish a precise reference for reflection measurements. Return loss is 0.18 dB \pm 0.1 dB (96% \pm 2%)



81000UM - Universal Feedthrough Adapter

To adapt 81000BR or HMS-10 connectors to any other appropriate connector. In combination with an Agilent 81000xI connector interface, this adapter allows you to mate an HMS-10 connector to another HMS-10, FC/PC/SPC, APC, DIN, ST, E-2000, or SC connector.

It can also be used to mate an Agilent 81000BR reference reflector to a connector under test. The Agilent 81000UM is a through adapter only. It can not be used at the fiber interfaces of the modules.



81000RI - High Return Loss Interface

- Return Loss = 36 dB typ.
- To adapt straight connectors to Power Sensor modules





Threaded Head Adapter

(Threaded adapter for 8152x Optical Heads, 8162x Optical Heads with 81624DD and 81628B Optical Heads)



81000FA	81000KA	81000PA	81000VA	81003LA
FC/PC	SC	E-2000	ST	LC/F3000
FC/APC				

Optical Head Adapter

These adapters are to be used with Agilent optical heads only. The connector adapters are needed to attach connectorized fibers.

Optical Head Adapters – with integral D-shape attachment for 8162xx optical head (except 81628B – see threaded version)



81001FA	81001KA	81001PA	81001LA	81001MA
FC/PC	SC	E-2000	LC/F3000	MU

81003TD - MPO/MTP Connector Adapter

Optical head adapter with integral D-shape attachment for 8162xx optical head (except 81628B) for connection of ribbon cables with MT/MPO connectors. The adapter has connector guide pins and should be used with female cable connectors.



81001ZA - Blank Adapter

Plug-in D-shape adapter for 8162x Optical Heads To be customized by customer

Doesn't match to 8152x and High Power Optical Heads



81624DD - D-shape Adapter

To connect threaded adapters to 8162x D-shape receptable. Included with new heads except 81628B. Remove for using head with D-shaped adapters.



Bare Fiber Adapters and Interfaces

The Agilent Bare Fiber Connectivity Solutions enable the easy and repeatable adaptation of optical components to Agilent's standard optical heads (all 8152x and 8162x series) and sensor modules 81630B, 81634B.



- 81000BC** Bare Fiber Connectivity Set for 81623B, 81624B and 81626B (1x head Adapter, 1x 0-400 um holder, 1x 400-900 um holder, 1x gauge)
- 81000BI** Bare Fiber Connectivity Set for 81630B and 81634B (1x sensor adapter, 1x 0-400 um holder, 1x 400-900 um holder, 1x gauge)
- 81000BT** Bare FC Set for 8152x and 8162x Optical Heads and threaded interface
- 81004BH** Bare Fiber Holder Set (10x 0-400 um holder)
- 81009BH** Bare Fiber Holder Set (10x 400-900 um holder)
- 81004BM / 9BM** Bare Fiber Holder Set (4x 0-400 um or 0-900 um holder)

N7740KI - SC

4-port SC connector for the multiport power meter series N7744A and N7745A.



N7740FI - FC



N7740BI - Bare Fiber Adapter

Fiber holders not included; please add 81004BM or 81009BM



N7740ZI - Zeroing Adapter



N7740LI - LC

4-port LC connector for the multiport power meter series N7744A and N7745A.

N7740MI - MU

4-port MU connector for the multiport power meter series N7744A and N7745A



Agilent Email Updates

www.agilent.com/find/emailupdates

Get the latest information on the products and applications you select.



www.axistandard.org AdvancedTCA®

Extensions for Instrumentation and Test (AXIe) is an open standard that extends the AdvancedTCA® for general purpose and semiconductor test. Agilent is a founding member of the AXIe consortium.



www.lxistandard.org

LAN eXtensions for Instruments puts the power of Ethernet and the Web inside your test systems. Agilent is a founding member of the LXI consortium.



<http://www.pxisa.org>

PCI eXtensions for Instrumentation (PXI) modular instrumentation delivers a rugged, PC-based high-performance measurement and automation system.

Agilent Channel Partners

www.agilent.com/find/channelpartners

Get the best of both worlds: Agilent's measurement expertise and product breadth, combined with channel partner convenience.



Agilent Advantage Services is committed to your success throughout your equipment's lifetime. We share measurement and service expertise to help you create the products that change our world. To keep you competitive, we continually invest in tools and processes that speed up calibration and repair, reduce your cost of ownership, and move us ahead of your development curve.

www.agilent.com/find/advantageservices



www.agilent.com/quality

Related Literature:

Lightwave Catalog Volume 2:
Transceiver Test 5989-6754EN

www.agilent.com

www.agilent.com/find/lightwave

For more information on Agilent Technologies' products, applications or services, please contact your local Agilent office. The complete list is available at:

www.agilent.com/find/contactus

Americas

Canada	(877) 894 4414
Brazil	(11) 4197 3500
Mexico	01800 5064 800
United States	(800) 829 4444

Asia Pacific

Australia	1 800 629 485
China	800 810 0189
Hong Kong	800 938 693
India	1 800 112 929
Japan	0120 (421) 345
Korea	080 769 0800
Malaysia	1 800 888 848
Singapore	1 800 375 8100
Taiwan	0800 047 866
Other AP Countries	(65) 375 8100

Europe & Middle East

Belgium	32 (0) 2 404 93 40
Denmark	45 70 13 15 15
Finland	358 (0) 10 855 2100
France	0825 010 700*
	*0.125 €/minute
Germany	49 (0) 7031 464 6333
Ireland	1890 924 204
Israel	972-3-9288-504/544
Italy	39 02 92 60 8484
Netherlands	31 (0) 20 547 2111
Spain	34 (91) 631 3300
Sweden	0200-88 22 55
United Kingdom	44 (0) 118 9276201

For other unlisted Countries:

www.agilent.com/find/contactus

Revised: October 14, 2010

Product specifications and descriptions in this document subject to change without notice.

© Agilent Technologies, Inc. 2010
Printed in USA, Nov. 1, 2010
5989-6753EN



Agilent Technologies